



# Variable Frequency Drive (VFD) Factory-Installed Option 2-Speed Motor Control for 2-Stage Cooling Rooftop Units

## Installation, Start-Up and Service Instructions

This document provides supplemental installation, setup and troubleshooting information for the Variable Frequency Drive (VFD) factory-installed option. It is to be used with the base unit Installation Instructions for 48/50TC, 50TCQ, 48/50HC, 50HCQ, and 40RU 2-Stage cooling units, sizes 07-30. Units equipped with the VFD are identified by an indicator in the unit's model number (see the unit's nameplate). Use Table 1 to identify whether a given unit is equipped with the factory-installed VFD option.

NOTE: Read the entire instruction manual before starting the installation.

### CONTENTS

<b>SAFETY CONSIDERATIONS</b> .....	1
<b>GENERAL</b> .....	2
<b>Staged Air Volume (SAV™) Indoor Fan Speed System</b> .....	2
<b>Identifying Factory Option</b> .....	2
<b>Unit Installation with SAV Option</b> .....	2
<b>Pre-Start Check, SAV Option</b> .....	5
<b>START-UP, SAV OPTION</b> .....	16
<b>Compressor Rotation</b> .....	16
<b>Indoor Fan Motor</b> .....	16
<b>Cooling with SAV</b> .....	16
<b>Operating Sequences, SAV Option</b> .....	17
<b>Cooling (FAN switch in AUTO)</b> .....	17
<b>Heating</b> .....	17
<b>Operating Fan for Test and Balance</b> .....	17
<b>SERVICE</b> .....	19
<b>SAV Option Components</b> .....	19
<b>Fan Speed Relay Board</b> .....	19
<b>Configuration Jumpers</b> .....	19
<b>Variable Frequency Drive</b> .....	19
<b>Central Terminal Board Jumpers (48/50 Series Only)</b> .....	21
<b>VFD Fuses</b> .....	22
<b>Control and Power Wiring Diagrams</b> .....	23
<b>VFD ALARMS AND FAULTS</b> .....	
<b>TROUBLESHOOTING</b> .....	30
<b>Alarms</b> .....	30
<b>Faults</b> .....	30
<b>VFD Maintenance</b> .....	30
<b>Heat Sink Cleaning</b> .....	31
<b>Bypass the VFD</b> .....	31
<b>BASIC VFD PARAMETERS</b> .....	32
<b>APPENDIX A — REMOTE VFD KEYPAD</b> .....	
<b>REFERENCE</b> .....	42

### SAFETY CONSIDERATIONS

#### ⚠ CAUTION

##### CONFIGURATION OVERRIDE HAZARD

DO NOT USE ABB OR CARRIER START-UP ASSISTANT ON THIS VFD APPLICATION! Use of start-up assistant will override the factory VFD configurations!

Improper installation, adjustment, alteration, service, maintenance, or use can cause explosion, fire, electrical shock or other conditions which may cause personal injury or property damage. Consult a qualified installer, service agency, or your distributor or branch for information or assistance. The qualified installer or agency must use factory-authorized kits or accessories when modifying this product. Refer to the individual instructions packaged with the kits or accessories when installing.

Follow all safety codes. Wear safety glasses and work gloves. Use quenching cloths for brazing operations and have a fire extinguisher available. Read these instructions thoroughly and follow all warnings or cautions attached to the unit. Consult local building codes and appropriate national electrical codes (in USA, ANSI/NFPA 70, National Electrical Code (NEC); in Canada, CSA C22.1) for special requirements.

It is important to recognize safety information. This is the safety-alert symbol ⚠. When you see this symbol on the unit and in instructions or manuals, be alert to the potential for personal injury.

Understand the signal words DANGER, WARNING, CAUTION, and NOTE. These words are used with the safety-alert symbol. DANGER identifies the most serious hazards which will result in severe personal injury or death. WARNING signifies hazards which could result in personal injury or death. CAUTION is used to identify unsafe practices, which may result in minor personal injury or product and property damage.

NOTE is used to highlight suggestions which will result in enhanced installation, reliability, or operation.

## GENERAL

### Staged Air Volume (SAV™) Indoor Fan Speed System

The Staged Air Volume (SAV) system utilizes a Fan Speed control board and Variable Frequency Drive (VFD) to automatically adjust the indoor fan motor speed in sequence with the unit's ventilation, cooling and heating operation. Per ASHRAE 90.1-2016 and IECC\*-2015 standards, during the first stage of cooling operation the SAV system will adjust the fan motor to provide 66% of the design airflow rate for the unit. When the call for the second stage of cooling is required, the SAV™ system will allow the design airflow rate for the unit established (100%). During the heating mode, the SAV system will allow total design airflow rate (100%) operation. During ventilation mode, the SAV system will operate the fan motor at 66% of full speed.

Figures 1 and 2 show the VFDs used for the SAV indoor fan speed system.



**Fig. 1 — ACH550 Variable Frequency Drive (VFD)**



**Fig. 2 — ACS320 Variable Frequency Drive (VFD)  
Identifying Factory Option**

This supplement only applies to units that meet the criteria detailed in Table 1. If the unit does not meet that criteria, discard this document.

NOTE: See Fig. 3 and 4 for examples of typical Model Number Nomenclature.

NOTE: 48/50LC units are not covered in this document; VFDs are standard equipment on belt drive LC units. VFD instructions for the 48/50LC series are found in the Installation Instructions for the LC base units.

**Table 1 — Model Size/VFD Option Indicator**

MODEL/SIZES	POSITION IN MODEL NUMBER	VFD FIOP INDICATOR
48/50TC / 07-30	17	G-M
50TCQ / 07-24	17	G-M
48/50HC / 07-28	17	G-M
50HCQ / 07-12	17	G-M
40RUA / 07-30	9	T
40RUS / 08-30	9	T
40RUQ / 07-25	9	T

### Unit Installation with SAV Option

#### 48/50HC, 50HCQ, 48/50TC, AND 50TCQ ROOFTOP

Refer to the base unit installation instructions for standard required operating and service clearances.

#### 40RU WITHOUT REMOTE VFD KEYPAD

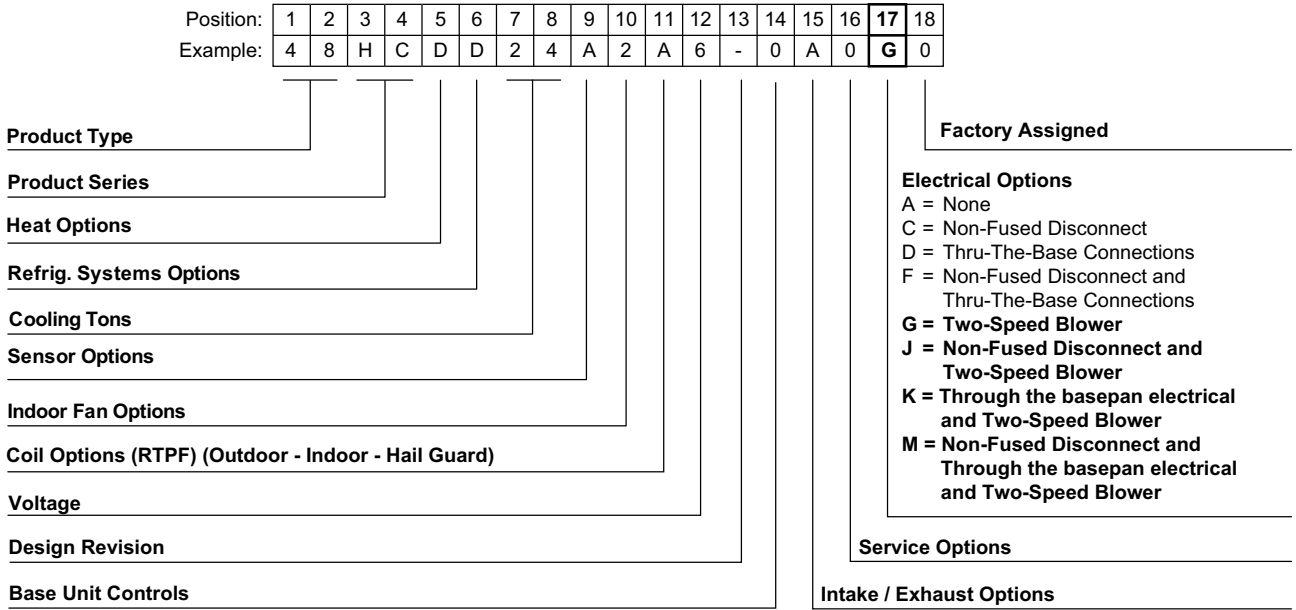
Additional service clearance is required on the rear for 40RU fan coil unit equipped with the SAV option. Increase the recommended rear panel clearance to 30 inches.

#### 40RU WITH REMOTE VFD KEYPAD

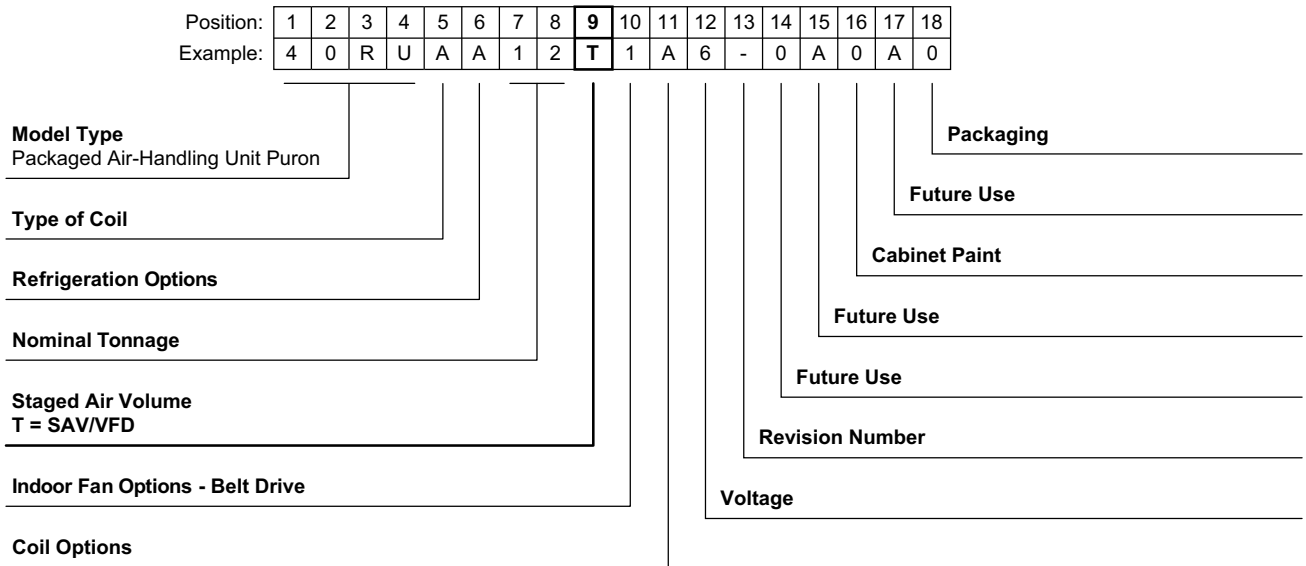
Refer to the base unit installation instructions for standard required operating and service clearances. Install the accessory remote VFD keypad before positioning the 40RU unit in its final operating location.

NOTE: The remote VFD keypad is a field-installed option. It is not included as part of the factory-installed VFD option.

\* IECC is a registered trademark of International Code Council, Inc.



**Fig. 3 — Model Number Nomenclature Example, 48/50-Series**



**Fig. 4 — Model Number Nomenclature Example, 40RU-Series**

**IMPORTANT:** Do NOT change units equipped with the VFD option to operate at less than the preset 66% minimum Hz setting (40 Hz). For example, do not change a unit equipped with a standard static motor to operate at less than 40 Hz (which is 66% of its 60 Hz rating).

Tables 2-10 list the minimum recommended CFM per fan motor type (single speed or 2-speed) for the units covered in this document.

**Table 2 — 48TC Min CFM Per Fan Motor Type**

MODEL-SIZE	SINGLE SPEED FAN MOTOR	2-SPEED FAN MOTOR (AT HIGH SPEED)	2-SPEED FAN MOTOR (AT LOW SPEED)
48TC 07	1800	1800	1188
48TC 08	2250	2250	1485
48TC 09	2550	2873	1896
48TC 12	3000	3380	2231
48TC 14	3600	4225	2789
48TC 16	4500	5625	3713
48TC 17	4500	4500	2970
48TC 20	5250	5250	3465
48TC 24	6000	6000	3960
48TC 28	7500	8450	5577
48TC 30	8250	8250	5445

**Table 3 — 50TC Min CFM Per Fan Motor Type**

MODEL-SIZE	SINGLE SPEED FAN MOTOR	2-SPEED FAN MOTOR (AT HIGH SPEED)	SPEED FAN MOTOR (AT LOW SPEED)
50TC 07	1800	1800	1188
50TC 08	2250	2250	1485
50TC 09	2550	2873	1896
50TC 12	3000	3380	2231
50TC 14	3600	4225	2789
50TC 16	4500	5625	3713
50TC 17	4500	4500	2970
50TC 20	5250	5250	3465
50TC 24	6000	6000	3960
50TC 28	7500	8450	5577
50TC 30	8250	8250	5445

**Table 4 — 50TCQ Min CFM Per Fan Motor Type**

MODEL-SIZE	SINGLE SPEED FAN MOTOR	2-SPEED FAN MOTOR (AT HIGH SPEED)	2-SPEED FAN MOTOR (AT LOW SPEED)
50TCQ 07	1800	1800	1188
50TCQ 08	2250	2535	1673
50TCQ 09	2550	2873	1896
50TCQ 12	3000	3000	1980
50TCQ 14	3750	4225	2789
50TCQ 17	4500	5070	3346
50TCQ 24	6000	6760	4462

**Table 5 — 48HC Min CFM Per Fan Motor Type**

MODEL-SIZE	SINGLE SPEED FAN MOTOR	2-SPEED FAN MOTOR (AT HIGH SPEED)	2-SPEED FAN MOTOR (AT LOW SPEED)
48HC 07	1800	1800	1300
48HC 08	2250	2535	1673
48HC 09	2550	2550	1683
48HC 11	3000	3380	2231
48HC 12	3000	3380	2231
48HC 14	3750	4225	2789
48HC 17	4500	5070	3346
48HC 20	5250	5915	3904
48HC 24	6000	7500	4950
48HC 28	7500	8450	5577

**Table 6 — 50HC Min CFM Per Fan Motor Type**

MODEL-SIZE	SINGLE SPEED FAN MOTOR	2-SPEED FAN MOTOR (AT HIGH SPEED)	2-SPEED FAN MOTOR (AT LOW SPEED)
50HC 07	1800	1800	1200
50HC 08	2250	2535	1673
50HC 09	2550	2550	1683
50HC 11	3000	3380	2231
50HC 12	3000	3380	2231
50HC 14	3750	4225	2789
50HC 17	4500	5070	3346
50HC 20	5250	5915	3904
50HC 24	6000	7500	4950
50HC 28	7500	8450	5577

**Table 7 — 50HCQ Min CFM Per Fan Motor Type**

MODEL-SIZE	SINGLE SPEED FAN MOTOR	2-SPEED FAN MOTOR (AT HIGH SPEED)	2-SPEED FAN MOTOR (AT LOW SPEED)
50HCQ 07	1800	1800	1188
50HCQ 08	2250	2250	1485
50HCQ 09	2550	2873	1896
50HCQ 12	3000	3380	2231

**Table 8 — 40RUA Min CFM Per Fan Motor Type**

MODEL-SIZE	SINGLE SPEED FAN MOTOR	2-SPEED FAN MOTOR (AT HIGH SPEED)	2-SPEED FAN MOTOR (AT LOW SPEED)
40RUA 07	1800	2030	1338
40RUA 08	2250	2535	1673
40RUA 12	3000	3380	2231
40RUA 14	3750	4225	2789
40RUA 16	4500	4500	2970
40RUA 25	6000	6000	3960
40RUA 28	7500	8450	5577
40RUA 30	9000	9295	6135

**Table 9 — 40RUS Min CFM Per Fan Motor Type**

MODEL-SIZE	SINGLE SPEED FAN MOTOR	2-SPEED FAN MOTOR (AT HIGH SPEED)	2-SPEED FAN MOTOR (AT LOW SPEED)
40RUS 08	2250	2535	1673
40RUS 10	2550	2873	1896
40RUS 12	3000	3380	2231
40RUS 14	3750	4225	2789
40RUS 16	4500	4500	2970
40RUS 25	6000	6000	3960
40RUS 28	7500	8450	5577
40RUS 30	9000	9295	6135

**Table 10 — 40RUQ Min CFM Per Fan Motor Type**

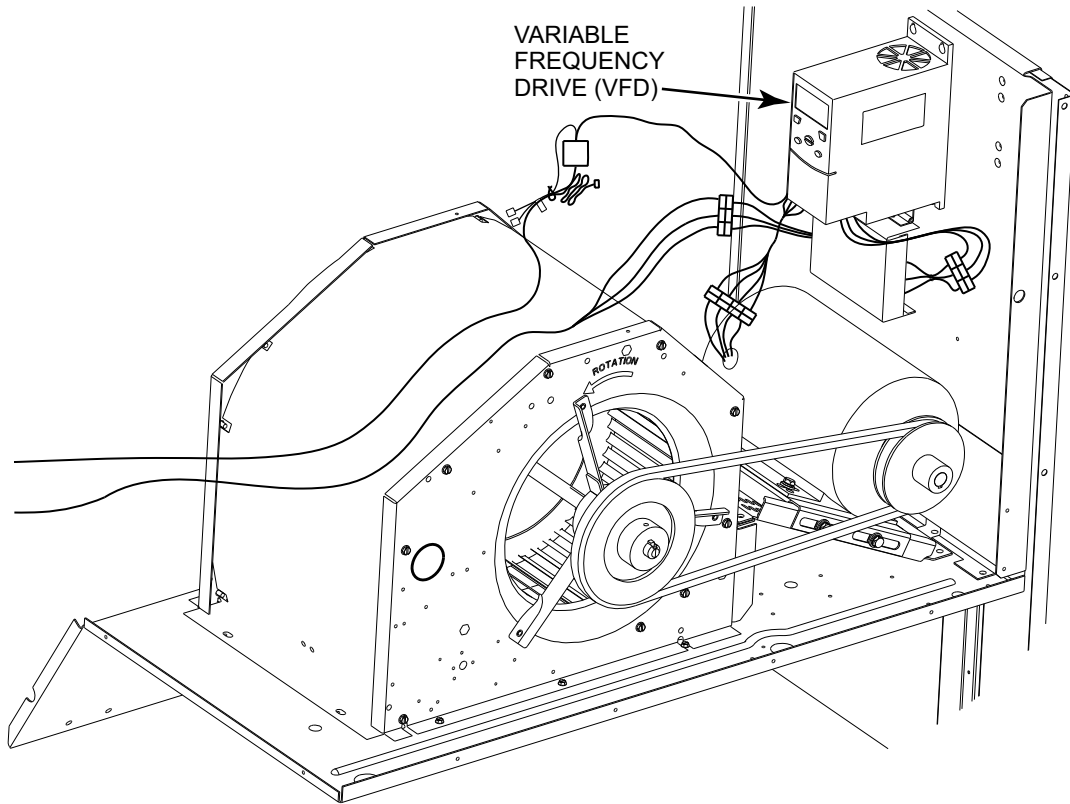
MODEL-SIZE	SINGLE SPEED FAN MOTOR	2-SPEED FAN MOTOR (AT HIGH SPEED)	2-SPEED FAN MOTOR (AT LOW SPEED)
40RUQ 07	1800	2030	1338
40RUQ 08	2250	2535	1673
40RUQ 12	3000	3380	2231
40RUQ 16	4500	4500	2970
40RUQ 25	6000	6000	3960

## Pre-Start Check, SAV™ Option

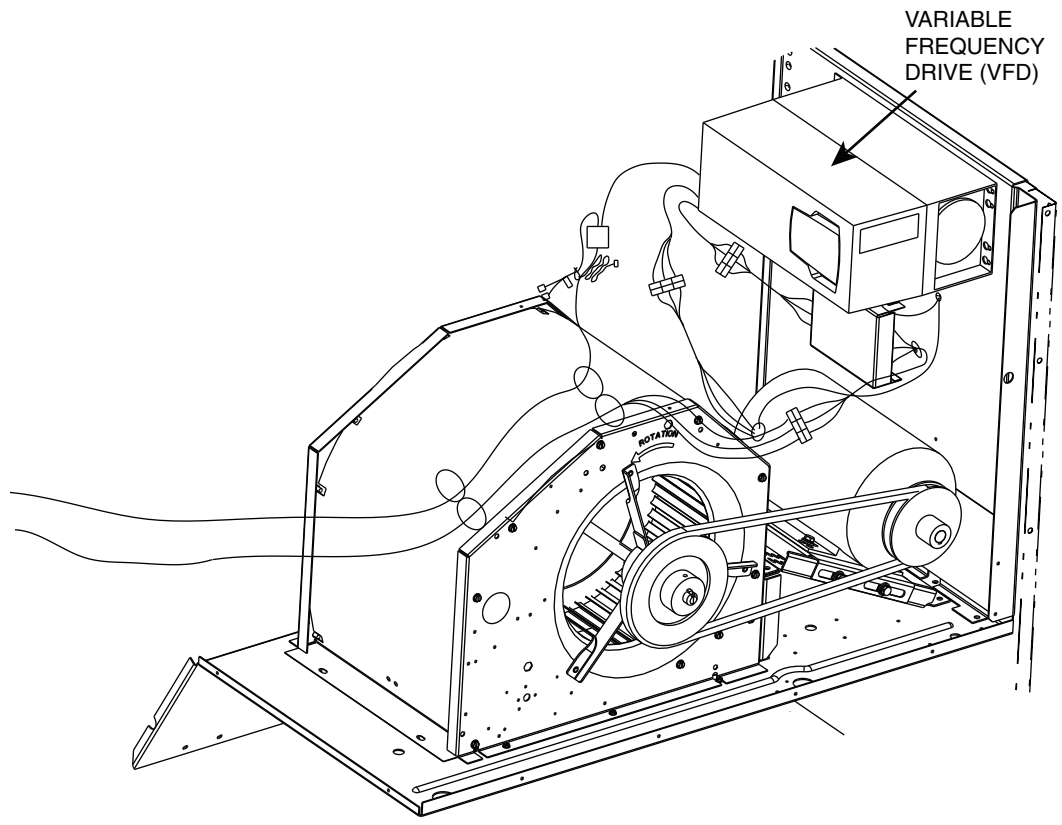
1. Remove the access panel to reach the VFD.
  - 48/50 Series: Blower compartment panel
  - 40RU: Rear access panel

NOTE: See Fig. 5-22 for VFD location in the units covered by this document.

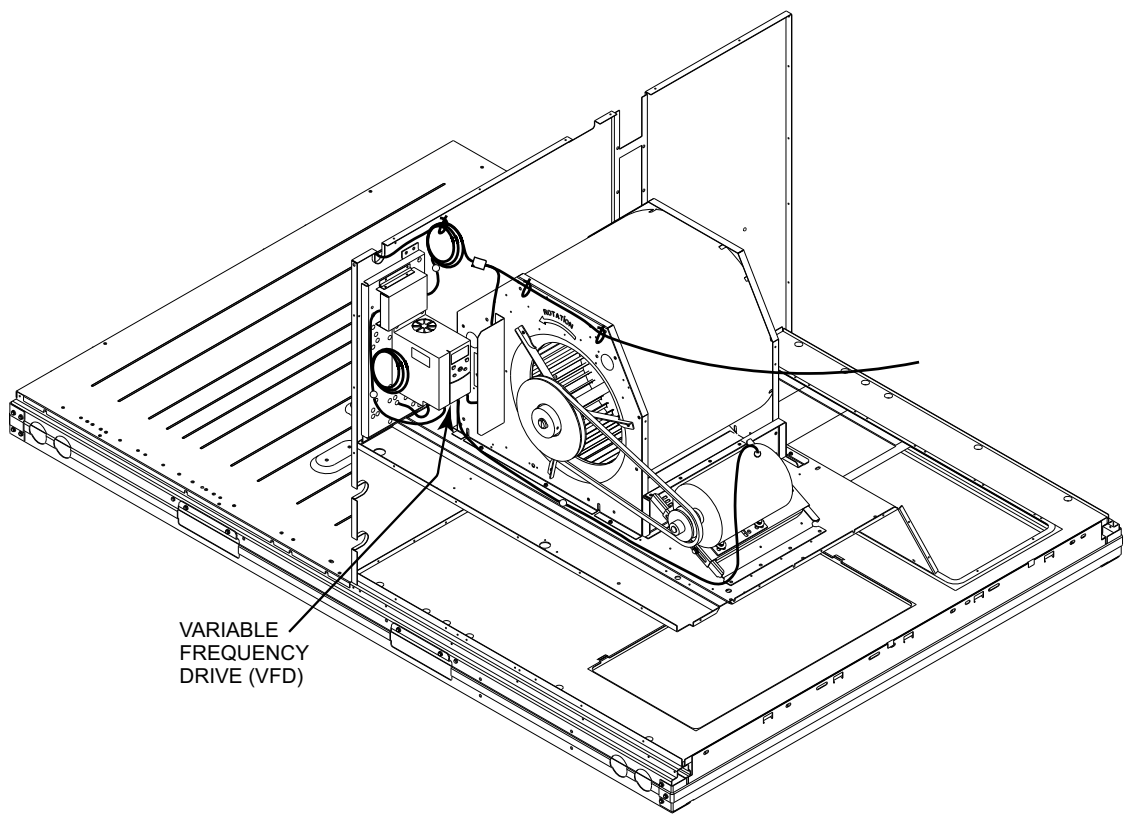
2. Read all safety, caution and warning labels.
3. Inspect wiring at the VFD for loose or disconnected wires at the terminal strip and for wires in contact with sharp edges and moving parts (pulley, belt).



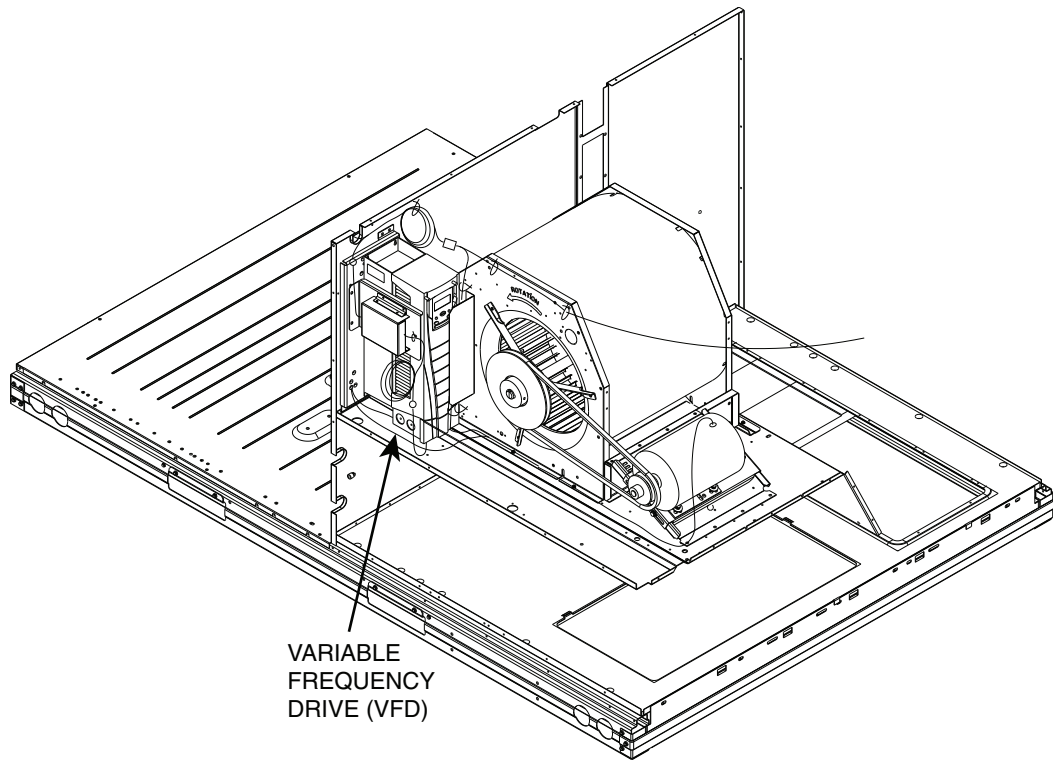
**Fig. 5 — ACS320 VFD Location for the following units: 48/50TC 07 and 50TCQ 07 (208/230V and 460V units only)**



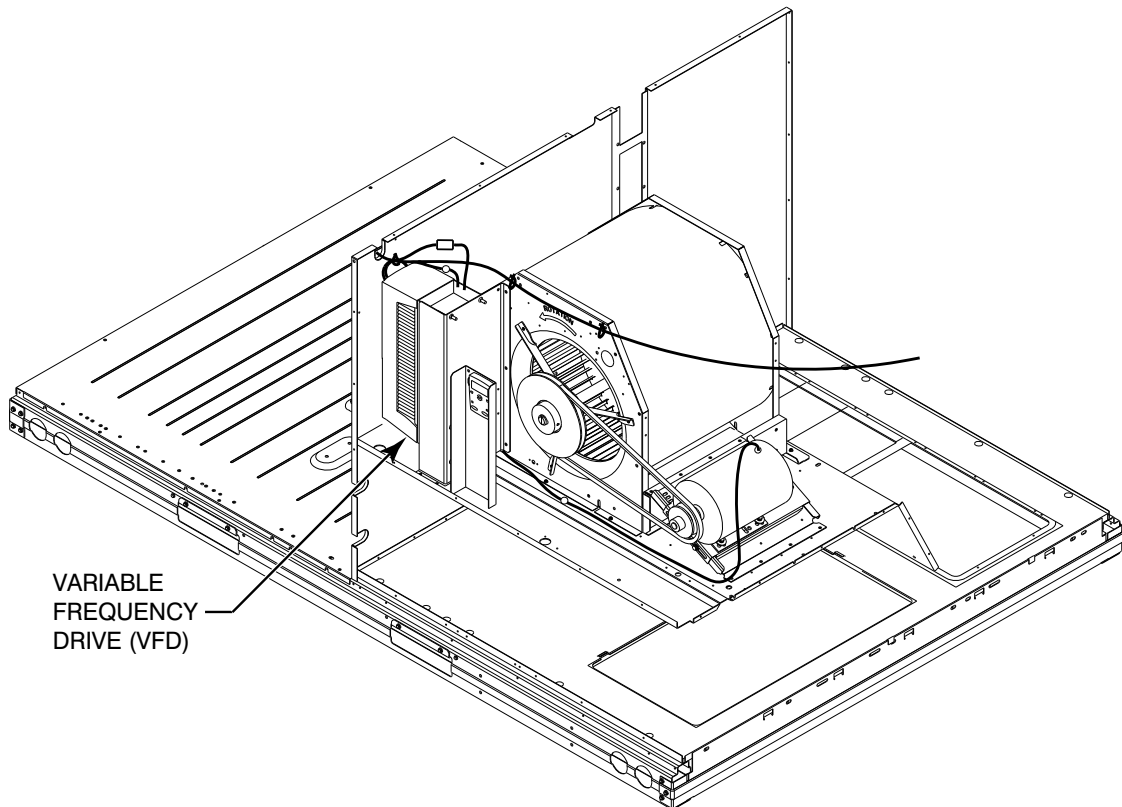
**Fig. 6 — ACH550 VFD Location for the following units: 48/50TC 07 (575V units only)**



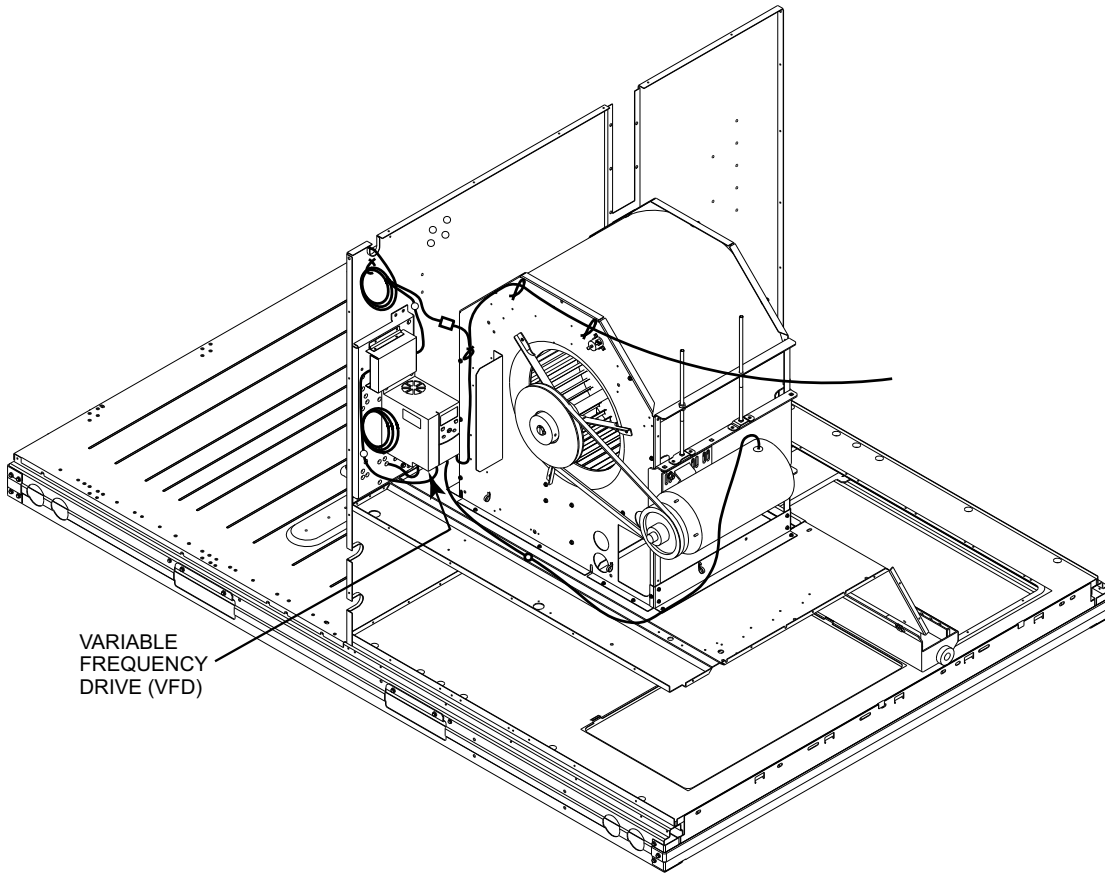
**Fig. 7 — ACS320 VFD Location for the following units: 48/50TC 08 (208/230V and 460V units only)**



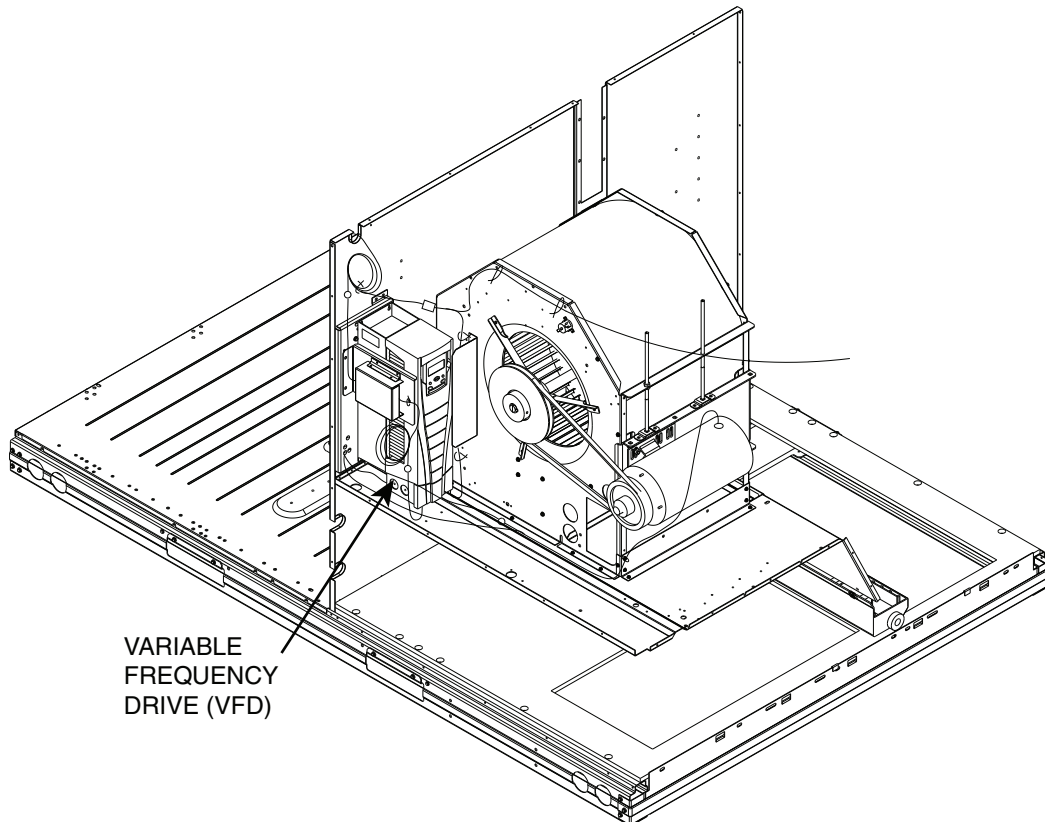
**Fig. 8 — ACH550 VFD Location for the following units: 48/50TC 08 (575V units only)**



**Fig. 9 — ACH550 VFD Location for the following units: 48/50HC 07 and 50HCQ 07**

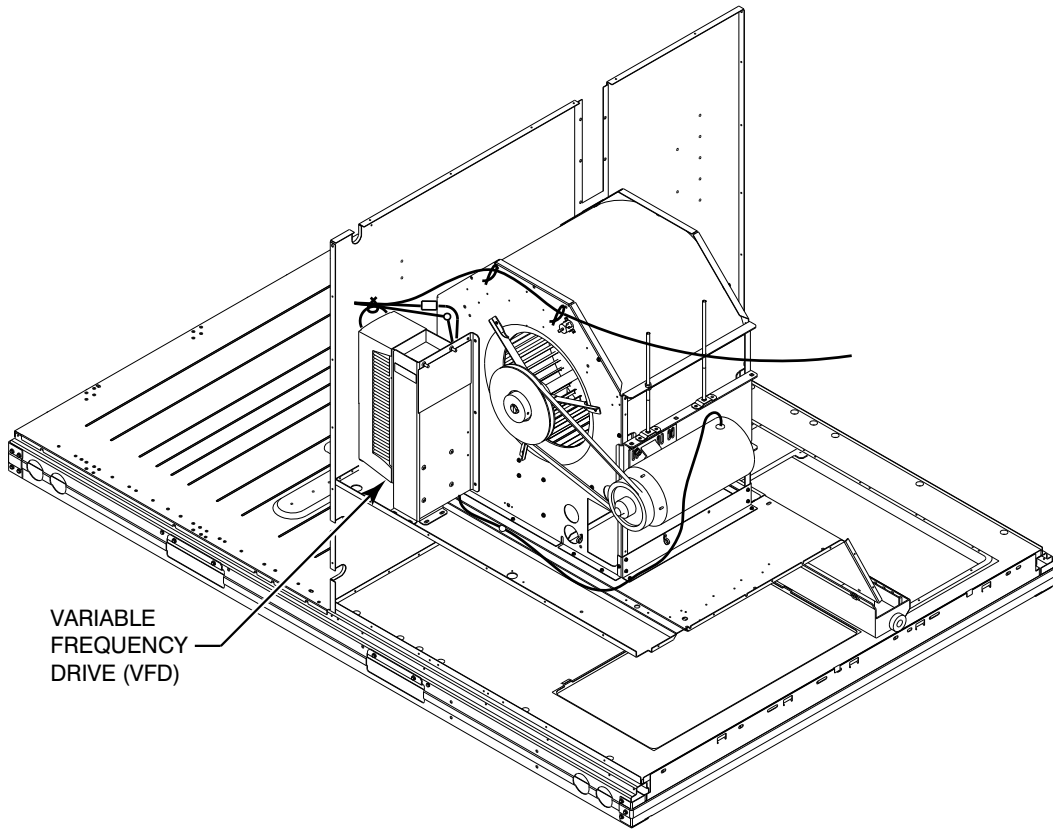


**Fig. 10 — ACS320 VFD Location for the following units: 48/50TC 09-14 and 50TCQ 08-12 (208/230V and 460V units only)**

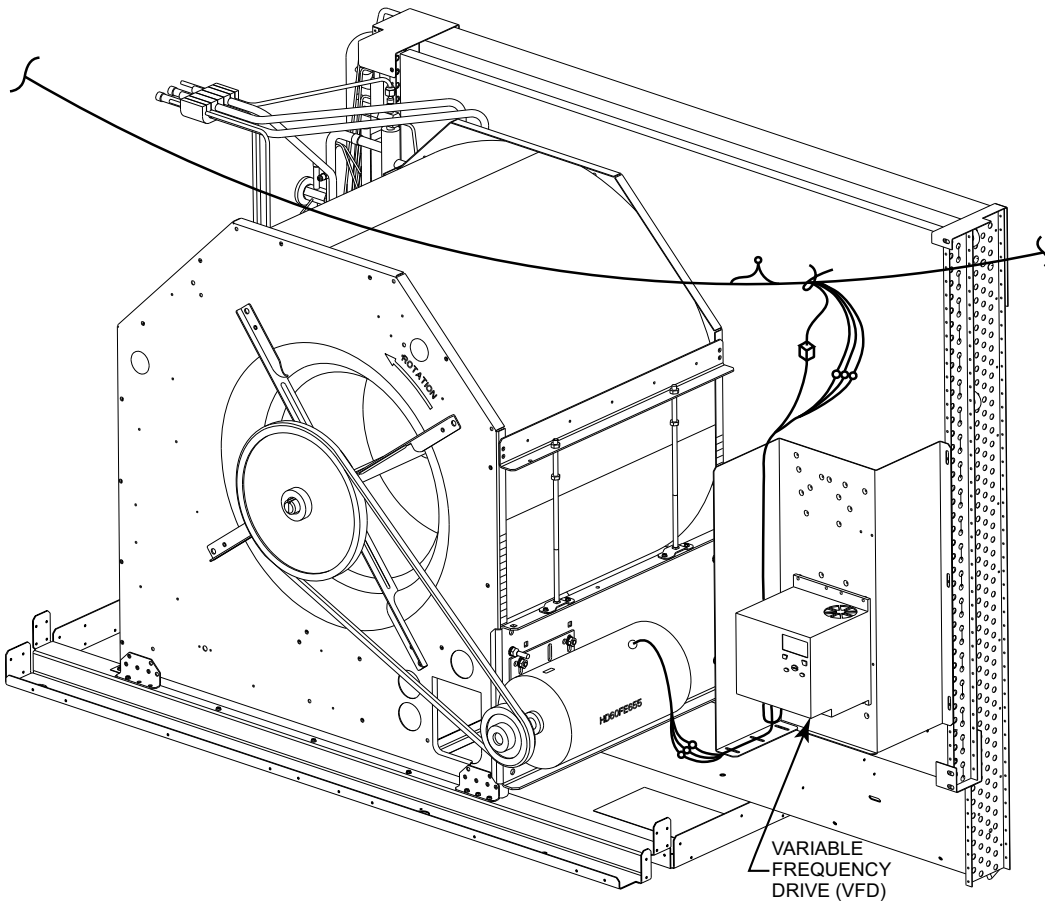


**Fig. 11 — ACH550 VFD Location for the following units: 48/50TC 09-14 and 50TCQ 08-12 (575V units only)**

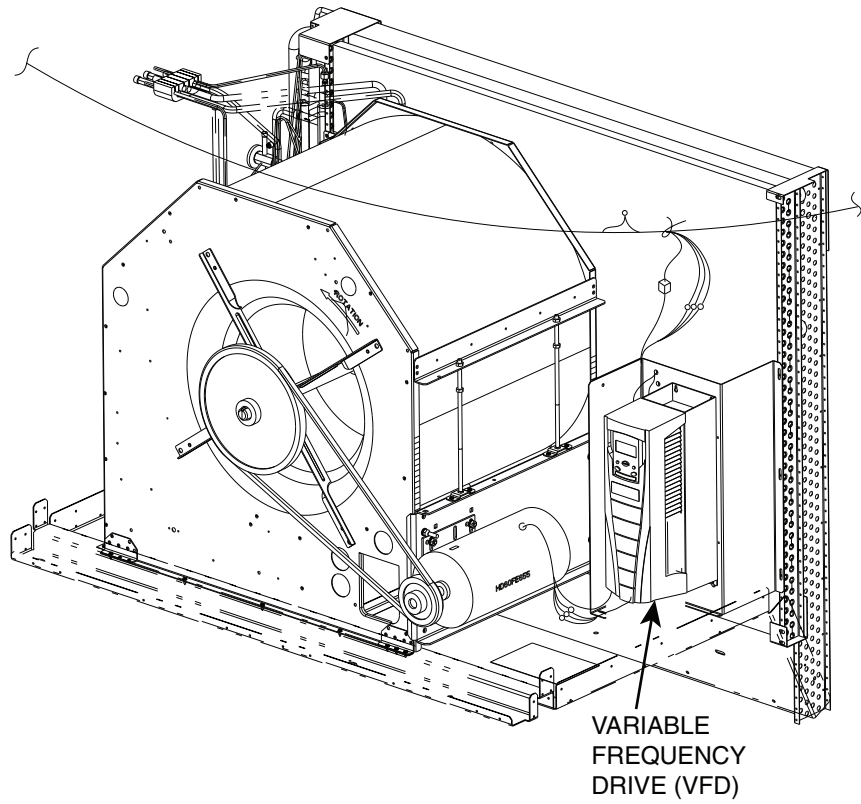




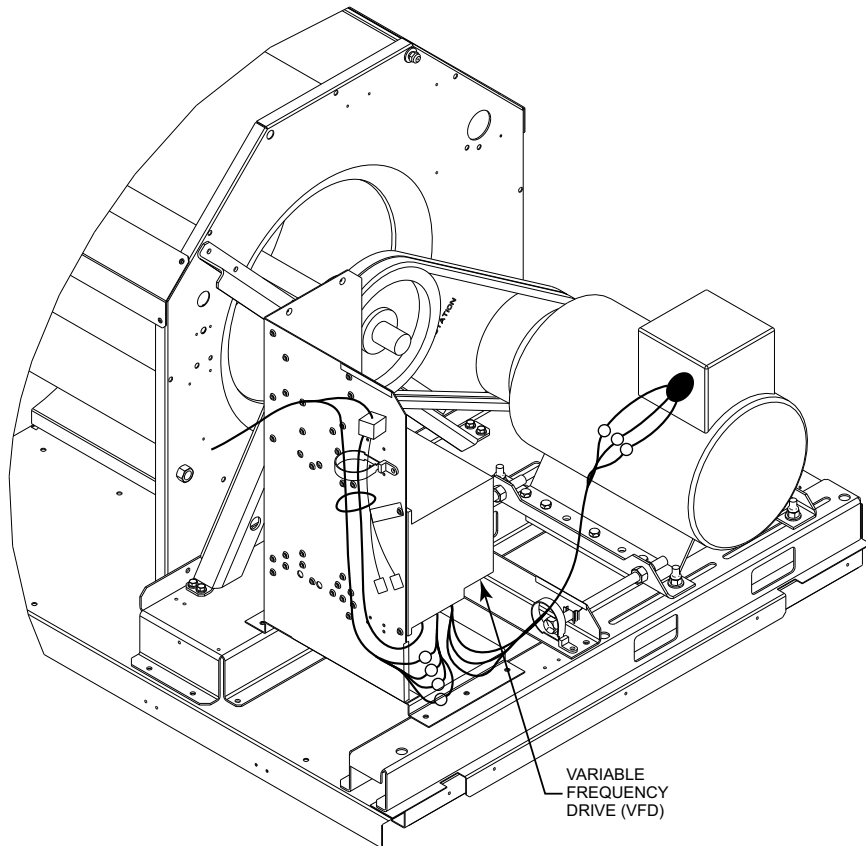
**Fig. 12 — ACH550 VFD Location for the following units: 48/50HC 08-09 and 50HCQ 08-09**



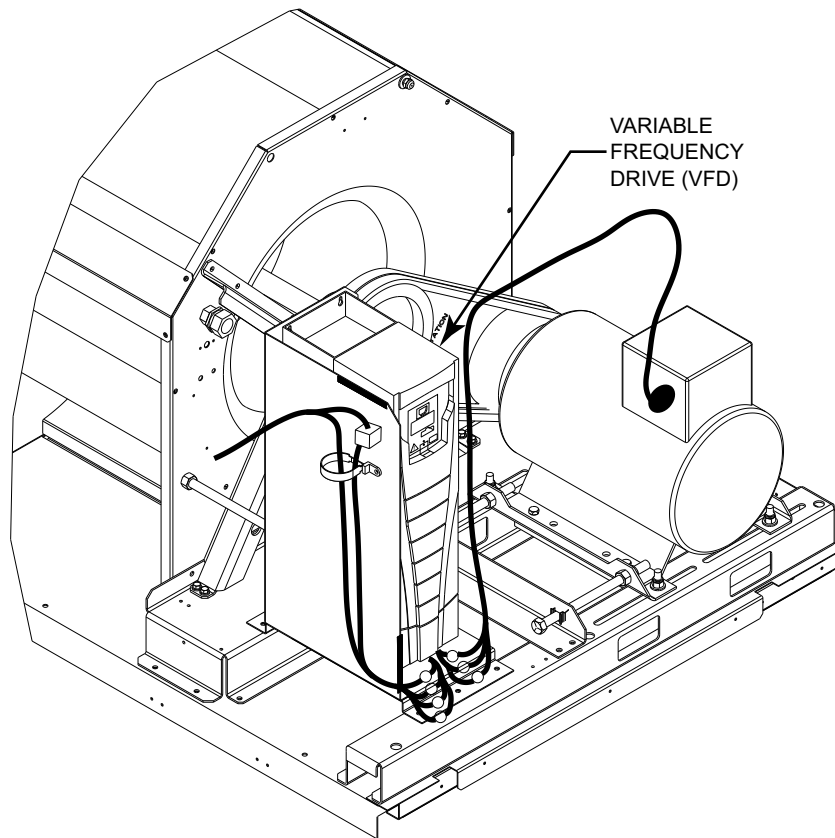
**Fig. 13 — ACS320 VFD Location for the following units: 48/50TC 16 and 50TCQ 14 (208/230V and 460V units only)**



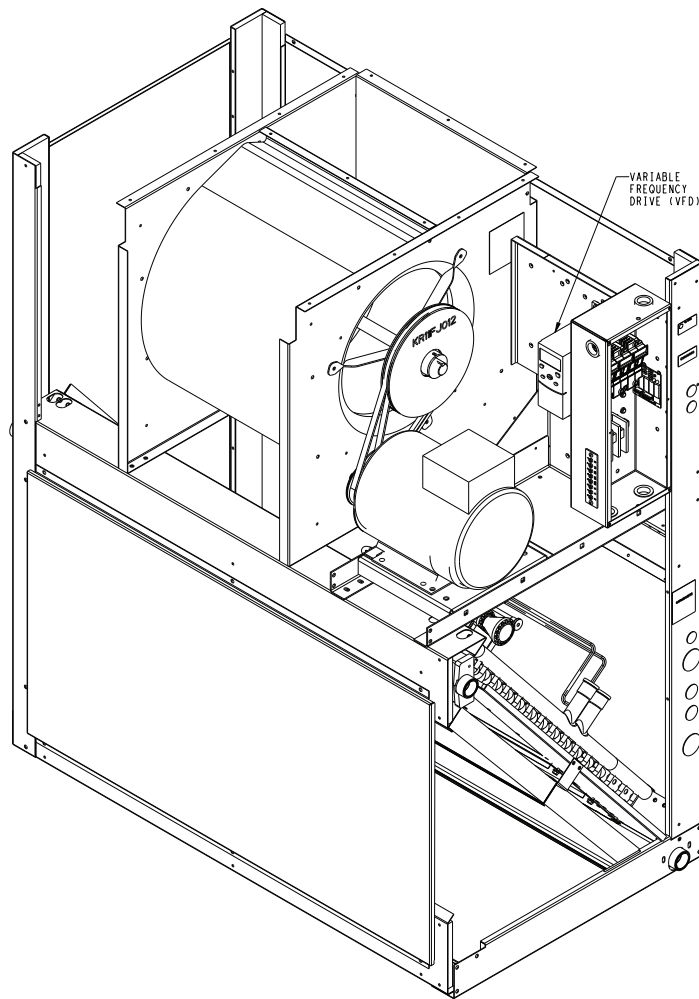
**Fig. 14 — ACH550 VFD Location for the following units: 48/50TC 16 and 50TCQ 14 (575V units only)**



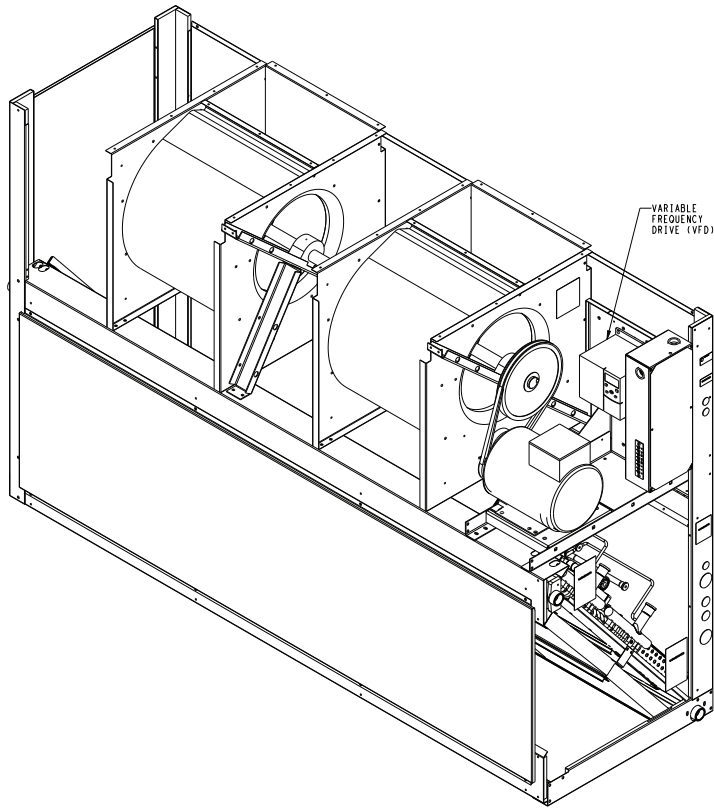
**Fig. 15 — ACS320 VFD Location for the following units: 48/50TC 17-30 and 50TCQ 17-24 (208/230V and 460V units only)**



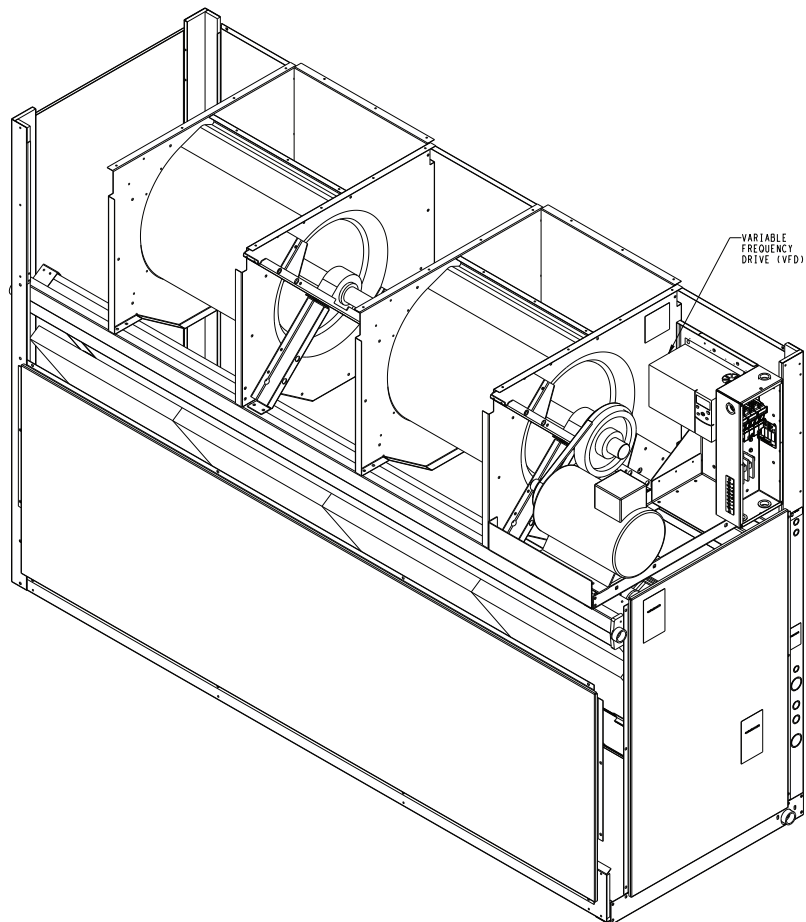
**Fig. 16 — ACH550 VFD Location for the following units: 48/50TC 17-30 and 50TCQ 17-24 (575V units only), 48/50HC 17-28**



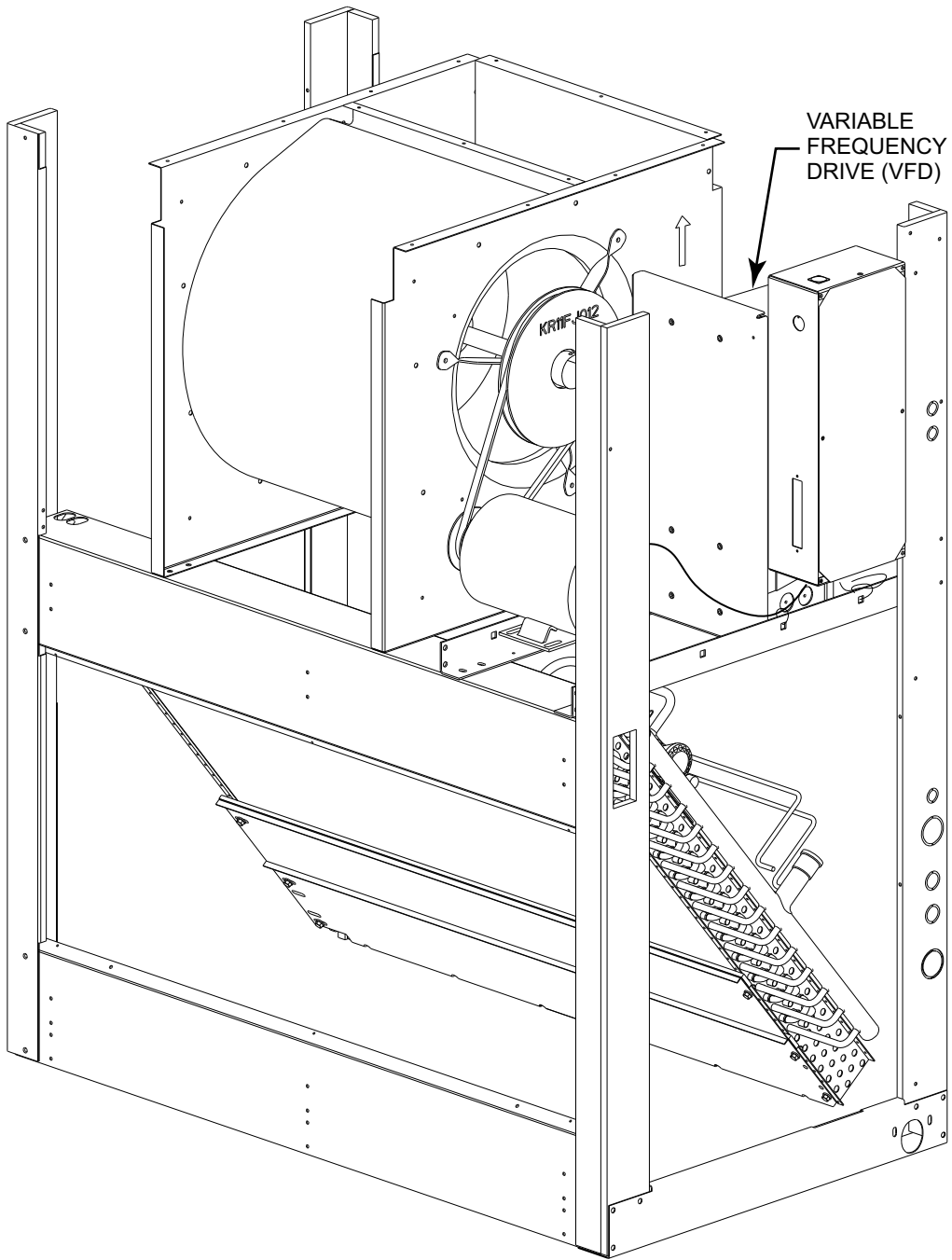
**Fig. 17 — ACS320 VFD Location for the following units: 40RUA/RUQ 07-12, 40RUS 08-12 (208/230V and 460V only)**



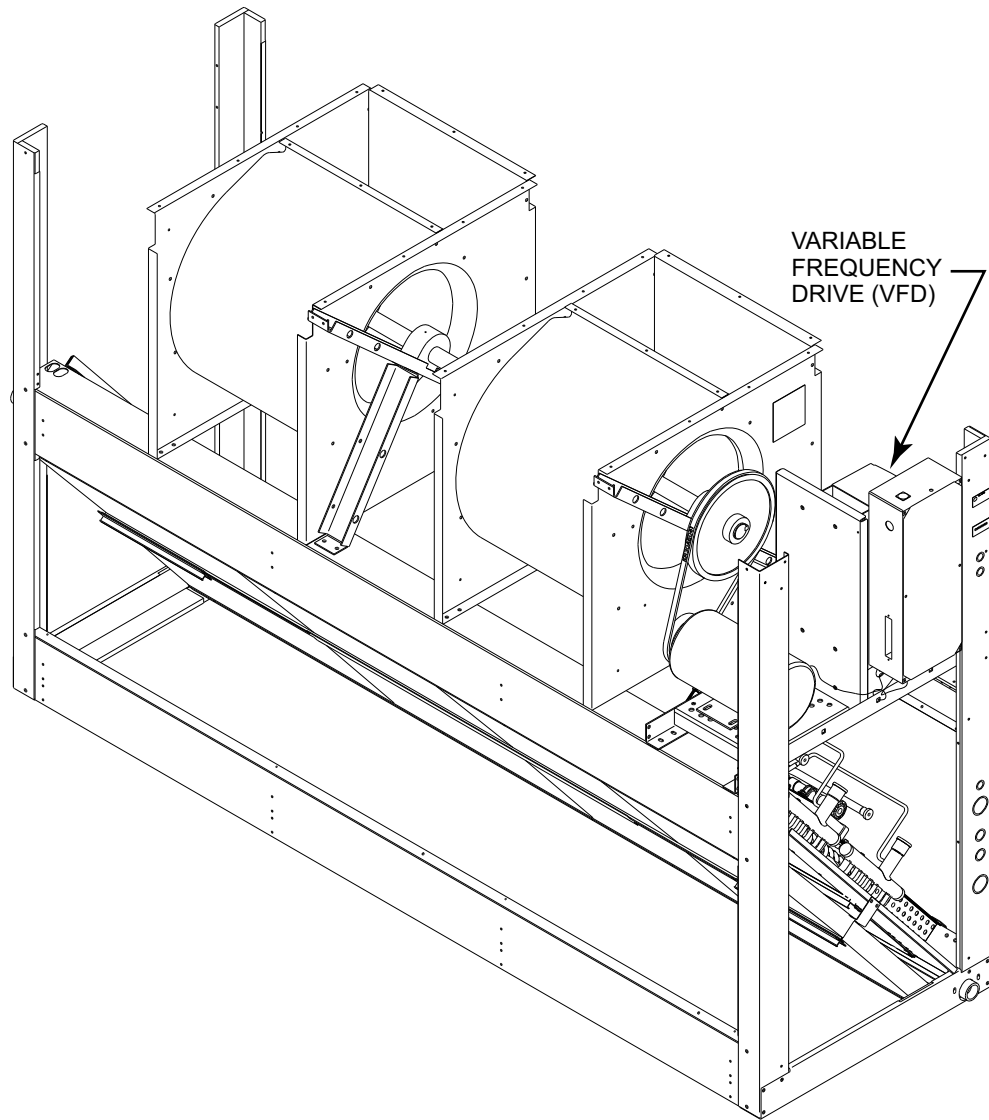
**Fig. 18 — ACS320 VFD Location for the following units: 40RUA/RUS 14-25, 40RUQ 16-25 (208/230V and 460V only)**



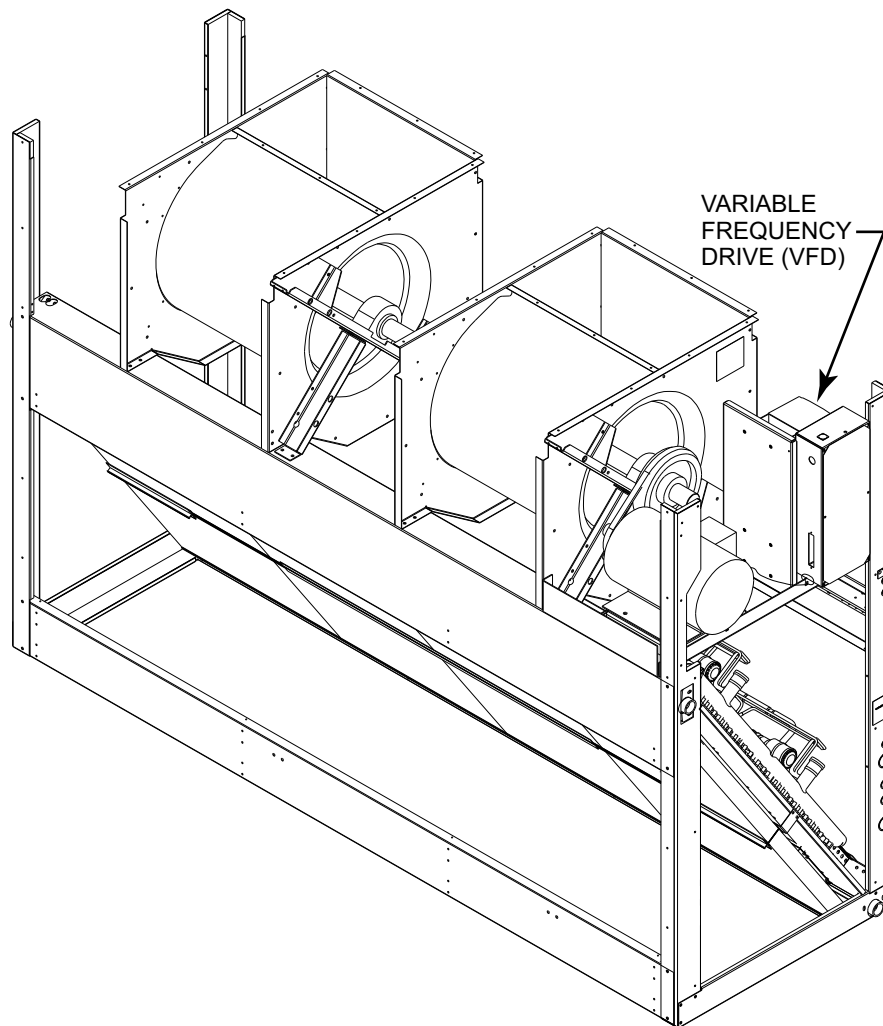
**Fig. 19 — ACS320 VFD Location for the following units: 40RUA/RUS 28-30 (208/230V and 460V only)**



**Fig. 20 — ACH550 VFD Location for the following units: 40RUA/RUQ 07-12, 40RUS 08-12 (575V only)**



**Fig. 21 — ACH550 VFD Location for the following units: 40RUA/RUS 14-25, 40RUQ 16-25 (575V only)**



**Fig. 22 — ACH550 VFD Location for the following units: 40RUA/RUS 28-30 (575V only)**

### **START-UP, SAV™ OPTION**

#### **Compressor Rotation**

Units equipped with a VFD on the indoor fan motor cannot use rotation direction of the indoor fan motor and fan to visually confirm a correct phase connection to the unit and compressors. Correct phases to equipment for proper compressor rotation. The VFD will maintain the same rotation as input phases are changed. Pressure gages **MUST BE USED** during cooling system start-up to confirm correct compressor rotation and operation.

#### **Indoor Fan Motor**

Raise the cooling set point at the space thermostat to higher than space temperature. Switch the thermostat's FAN switch to CONT (Continuous) position. Fan motor will start, run at reduced speed.

Check for fan rotation direction. To reverse the fan rotation, disconnect all power to unit and then switch two motor power leads between the VFD and the motor. Restore unit power and recheck fan rotation direction.

Check fan motor speed. Motor shaft should be rotating at 1150 to 1180 RPM (19.2 to 19.7 r/s).

Switch the thermostat's FAN switch to AUTO position. Fan motor will stop.

#### **Cooling with SAV**

##### **FIRST STAGE (Y1)**

Set the thermostat FAN switch to AUTO and the SYSTEM switch to COOL. Slowly lower the cooling set point until first stage compressor starts. Indoor fan motor also starts, runs at reduced speed.

##### **SECOND STAGE (Y2)**

Lower the cooling set point until second stage compressor starts. Indoor fan motor will switch to high speed.

Check fan motor speed. Motor shaft should be rotating at 1725 to 1760 RPM (28.8 to 29.3 r/s).

Confirm compressors are running at correct rotation by checking suction and discharge pressures. To reverse the compressor rotation, disconnect unit power and switch two of the unit's main power leads. Restore unit power and recheck compressor operation.

Reset thermostat cooling set point to a position above space temperature. Both compressors will shut off. Indoor fan motor will stop immediately.

##### **40RU, 50 SERIES UNITS**

Indoor fan motor will stop immediately.

##### **48 SERIES UNITS**

Indoor fan operation will continue for 45-seconds, then stop.



## Operating Sequences, SAV Option

### VENTILATION (FAN ONLY)

Ventilation mode occurs when the indoor fan runs without accompanying cooling or heating system operation. The thermostat's FAN selection switch will be in CONT (Continuous) position; no demand for cooling or heating will be present.

### 48 SERIES UNITS

The thermostat's G terminal is energized with 24-v. This signal is conveyed to the 48 Series unit's Central Terminal Board (CTB) at the field connection TSTAT terminal strip at terminal G. The 24-v signal follows an internal trace path through jumper JMP6 to connector CONTL BOARD pin 1. A harness wire connects pin 1 to IGC board terminal G. The IGC energizes its fan relay, energizing IGC terminal IFO. This 24-v signal follows a harness conductor back to the CTB's CONTL BOARD connector at pin 6 and pin 7. Pin 7 is connected to the Fan Speed Board at connector J1 pin 4. Relay K3 is energized. A 24-VDC signal is passed to the VFD terminal 14. The VFD starts the indoor fan motor and runs it at 40 Hz for reduced/low speed operation.

### 50HC, TC SERIES UNITS

The thermostat's G terminal is energized with 24-v. This signal is conveyed to the 50HC,TC Series unit's Control Terminal Board (CTB) at the field connection TSTAT terminal strip at terminal G. The 24-v signal follows an internal trace path through jumper JMP6 to connector CONTL BOARD pin 1. A harness wire connects pin 1 to the Fan Speed Board at connector J1 pin 4. Relay K3 is energized. A 24-VDC signal is passed to the VFD terminal 14. The VFD starts the indoor fan motor and runs it at 40 Hz for reduced/low speed operation.

### 50HCQ, TCQ SERIES

The thermostat's G terminal is energized with 24-v. This signal is conveyed to the 50HCQ,TCQ Series unit's Control Terminal Board (CTB) at the field connection TSTAT terminal strip at terminal G. The 24-v signal follows an internal trace path to connector REHEAT/DEFROST pin 1. A harness wire connects pin 1 to DFB board terminal P2-3. The DFB energizes its fan relay, energizing DFB terminal P3-8. This 24-v signal follows a harness conductor back to the CTB's REHEAT/DEFROST pin 2. An internal trace path connects pin 2 to CONTL BOARD connector at pin 1. Pin 1 is connected to the Fan Speed Board at connector J1 pin 4. Relay K3 is energized. A 24-VDC signal is passed to the VFD terminal 14. The VFD starts the indoor fan motor and runs it at 40 Hz for reduced/low speed operation.

## Cooling (FAN Switch in AUTO)

### FIRST STAGE (Y1)

When the thermostat initiates a call for First Stage Cooling by closing its Y1 contacts, the thermostat also energizes its G terminal. Follow the sequence under Ventilation above. Fan Speed Relay board relay K3 is energized, causing the VFD to start the indoor fan motor and run at 40 Hz for reduced fan speed operation.

When space temperature drops to satisfy the thermostat Y1 demand, contact Y1 opens de-energizing terminal G. Relay K3 is de-energized. The relay board output at J2-2 to the VFD is removed and indoor fan motor ramps down to stop.

### SECOND STAGE (Y2)

If space temperature continues to rise, thermostat Y2 demand will be initiated. Contact Y2 will close, sending a 24-v signal to CTB's TSTAT terminal strip at Y2. An internal path passes this signal to connector DDC/TSTAT pin 6. A harness wire carries this signal to Fan Speed Relay board pin J1-3. Relay K2 is energized. The relay board's output to VFD at pin J2-2 is de-energized and the output at J2-3 is energized, causing the VFD

to shift its output to the indoor fan motor to 60 Hz. The indoor fan motor ramps up to full/high speed operation.

When the space temperature drops to satisfy thermostat Y2 demand, contact Y2 opens de-energizing terminal Y2. Relay K2 is de-energized, removing the VFD input at terminal 15. Fan Speed Board output at pin J2-2 is restored to the VFD at terminal 14; VFD shifts back to 40 Hz output to the indoor fan motor and motor shifts back to reduced speed operation.

## Heating

When the thermostat initiates a call for First Stage Heating by closing its W1 contacts, a 24-v signal is conveyed to the CTB's TSTAT terminal strip at W1. An internal path passes this signal to connector DDC/TSTAT pin 5. A harness wire carries this signal to Fan Speed Relay board pin J1-2. Relay K1 is energized. The relay board's output to VFD at pin J2-3 is energized, providing a 24-VDC signal to VFD terminal 15. The VFD starts the indoor fan motor, runs at 60 Hz for full/high speed operation.

When space temperature rises to satisfy the thermostat W1 demand, contact W1 opens de-energizing terminal W1. Relay K1 is de-energized. The relay board output at J2-3 to the VFD is removed.

### 40RU, 50-SERIES

Indoor fan motor ramps down to stop.

### 48-SERIES

The IGC's fan-off delay sequence will energize relay K3 for 45-seconds, causing the VFD to operate the indoor fan motor at 40 Hz (low speed) for 45-seconds, then indoor fan motor will ramp down to stop.

## Operating Fan for Test and Balance

During the Test and Balance procedure, it is necessary to operate the supply fan in High Speed without concurrent operation of the Cooling or Heating systems. Use the following procedure to force the fan speed to High.

### UNITS WITHOUT ACCESSORY KEYPAD

1. Set the space thermostat to SYSTEM OFF and FAN in AUTO.
2. Disconnect unit power. Lock-out/tag out.
3. Open the fan access panel and locate the VFD (see Fig. 5-22 for your specific unit).
4. Locate and connect the WHT and YEL wires extending from the VFD. The two wires are bundled together using the label shown in Fig. 23.

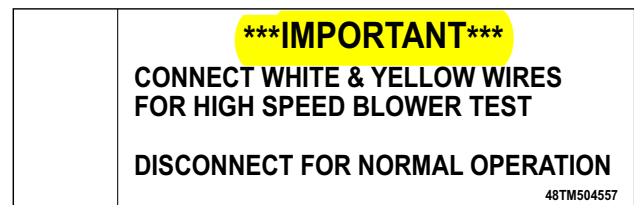


Fig. 23 — High Speed Test Label

5. Locate pressure ports or pitot tubes in the return duct and supply duct to measure external static pressure. See Fig. 24 for typical locations.
6. Restore unit power.
7. Set the space thermostat to FAN CONT.
8. Check the motor speed with stroboscope or similar tool. Motor shaft speed must be in 1725 to 1760 RPM (28.8 to 29.3 r/s) range for High Speed.
9. Replace the fan access panel.
10. Perform test and balance procedure.

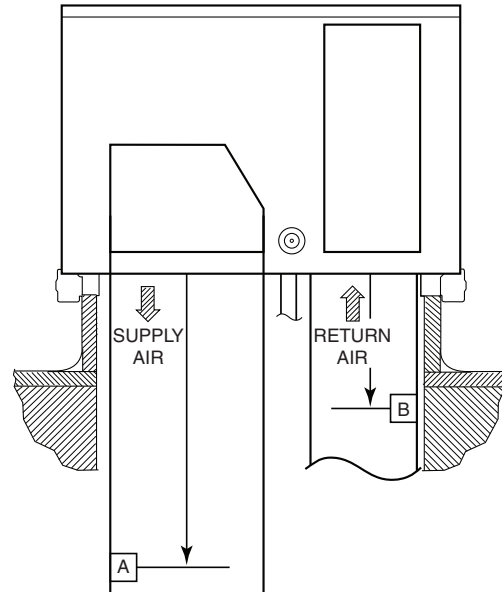
- Adjust the supply fan speed according to base unit instructions to deliver the project selection CFM value. Ensure the selection CFM value is not lower than the “Min CFM Per Fan Motor Type” for this unit-size as found in Tables 2-10 on page 4.

To restore the unit to ready-to-start condition, disconnect the unit power and lock-out/tag-out, set the space thermostat to FAN AUTO, remove the test pressure ports from the external duct locations, and disconnect the WHT and YEL wires. Replace the supply fan access panel. Restore unit power.

**UNIT WITH ACCESSORY VFD KEYPAD**

- Set the space thermostat to SYSTEM OFF and FAN in AUTO.
- Disconnect unit power. Lock-out/tag-out.
- Open the fan access panel (see Fig. 5-22 for specific unit).
- Locate pressure ports or pitot tubes in the return duct and supply duct to measure external static pressure. See Fig. 24 for typical locations.
- Restore unit power.
- Set the space thermostat to FAN CONT.
- At the VFD keypad, tap the HAND key and then tap the UP arrow button to increase the motor speed until 60.0 is displayed on the display screen.
- Check the motor speed with stroboscope or similar tool. Motor shaft speed must be in 1725 to 1760 RPM (28.8 to 29.3 r/s) range for High Speed.
- Replace the fan access panel.
- Perform Test and Balance procedure.
- Adjust the supply fan speed according to base unit instructions to deliver the project selection CFM value. Ensure the selection CFM value is not lower than the “Min CFM Per Fan Motor Type” for this unit-size as found in Tables 2-10 on page 4.

To restore the unit to ready-to-start condition, tap the DOWN arrow button to reduce motor speed until the 40.0 is displayed on the display screen and then tap the AUTO key. Disconnect the unit power and lock-out/tag-out, set the space thermostat to FAN AUTO. Remove the test pressure ports from the external duct locations. Restore unit power.



AHRI PRESSURE LOCATIONS					
MODEL	SIZES	IN	IN	MM	MM
		Supply Air	Return Air	Supply Air	Return Air
		[A]	[B]	[A]	[B]
48/50HC	07-12	43.5	12	1100	310
	14	64.5	14	1640	350
	17-28	83	19	2110	490
48/50TC	07	32	10	830	260
	08-14	43.5	12	1100	310
	16	64.5	14	1640	350
50HCQ	17-30	83	19	2110	490
	07-09	43.5	12	1100	310
	12	44.5	13	1130	330
50TCQ	07	32	10	830	260
	08-12	43.5	12	1100	310
	14	44.5	14	1130	350
	17-24	83	19	2110	490

**Fig. 24 — Measuring External Static Pressure — Distance Below Unit Base**

## SERVICE

### ⚠ CAUTION

#### EQUIPMENT DAMAGE HAZARD

Failure to follow this caution will result in equipment damage.

**Do NOT** exceed the recommended minimum Hz or CFM settings. Operating these units at a Hz setting below 40 Hz or at a CFM below the minimums listed in Tables 2-10 (page 4) will result in damage to the unit.

Figures 5-22 show the location of the VFD option in the various units covered by this document.

### SAV™ Option Components

The SAV factory option is comprised of three major components and related connecting harnesses:

1. Fan Speed Relay Board
2. Variable Frequency Drive
3. Indoor Fan Motor, designed for use with VFD

### Fan Speed Relay Board

This board (P/N HK50ZA002) is designated as the VFD Fan Board on the unit wiring diagram labels. It is a small (3.0 x 3.12 in., 76 x 79 mm) printed circuit board with four SPDT control relays. See Fig. 25. There is no software on this board. The relay board is located in the unit's main control box; refer to unit label diagram for Component Location view.

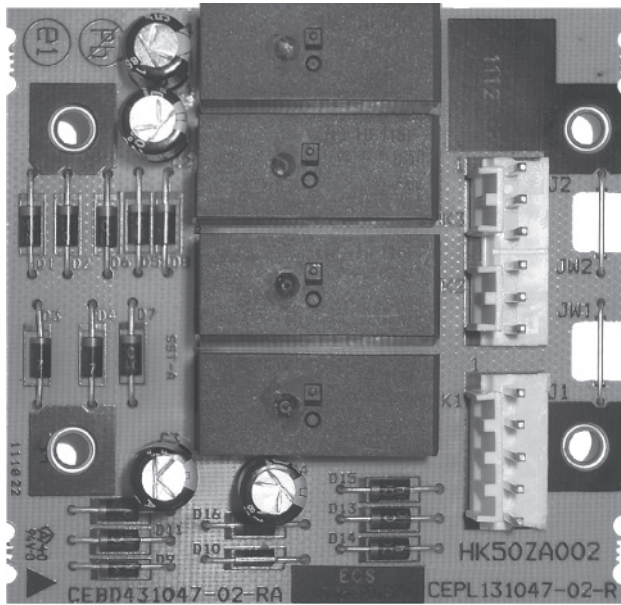


Fig. 25 — VFD Fan Board

The board is arranged in two separate circuits with individual pin connectors. Connector J1 is connected to the 24-vac input signal circuit with the four relay coils. Connector J2 is connected to the 24-VDC output circuit that connects to the VFD's terminal strip. See Fig. 27 (on page 20) for a simplified connection schematic for Fan Speed Relay board and the VFD.

In this SAV application, there are three inputs to the relay board, originating from the space thermostat's G, Y2 and W1 terminals. An input from terminal G (for continuous fan operation for ventilation or from a Y1 call) will result in the VFD starting the indoor fan motor and running the motor at LOW speed. An input from either Y2 or W1 will result in the VFD running the indoor fan motor at HIGH speed. See Table 11 for relay operation for each unit mode. Relay K4 is not used in this 2-speed application.

Table 11 — Two-Speed Configuration Logic (Thermostat Control)

INPUT	RELAY COIL STATUS			CONTROLLING OUTPUT	FAN MOTOR SPEED
	K1	K2	K3		
G	Off	Off	On	K3	Low (40 Hz)
Y1	Off	Off	On	K3	Low (40 Hz)
Y2	Off	On	On	K2	High (60 Hz)
W1	On	On	On	K1	High (60 Hz)

### Configuration Jumpers

The relay board has two configuration jumpers, marked JW1 and JW2. For this 2-speed motor application, both jumpers must be cut and open (see Fig. 26). Factory-installed boards will have these jumpers cut. Service replacement boards have these jumpers intact; servicer must cut both jumpers when installing a new service board. Failure to cut these jumpers will cause continuous fan motor operation.

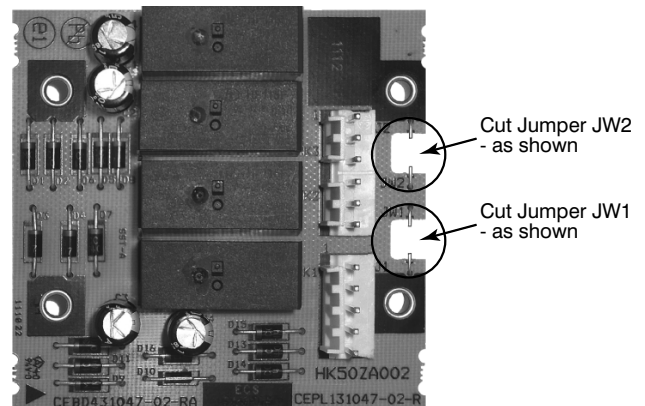


Fig. 26 — Jumpers JW1 and JW2 Cut for Two-Speed Fan Board Configuration

### Variable Frequency Drive

The VFD switches the indoor fan motor speed between full/high speed (60 Hz motor operation) and reduced/low speed (40 Hz motor operation) as required by ASHRAE 90.1-2016 and IECC-2015 requirements for two-stage HVAC units. The VFD is factory-configured to match the current and power requirements for each motor selection and all wiring connections are completed by the factory; no field adjustments or connections are necessary.

While the basic VFD retains all of its standard capabilities, the SAV 2-speed application uses only a limited portion of these features to provide two discrete output speeds to the motor. Consequently the VFD is not equipped with a keypad. A keypad is available as an accessory (P/N CRDISKIT001A00) for field-installation or expanded service access to VFD parameter and troubleshooting tables. Refer to Appendix A for expanded discussion on VFD parameters and factory settings.

### ⚠ CAUTION

#### CONFIGURATION OVERRIDE HAZARD

**DO NOT USE ABB OR CARRIER START-UP ASSISTANT ON THIS VFD APPLICATION!** Use of start-up assistant will override the factory VFD configurations!

The SAV control circuit inputs to the VFD are 24-VDC signals.

- For ACS320 VFDs the voltage is sourced from the VFD at its terminal 9 (+24 V). SAV speed inputs are received at terminals 13 (DI-2) for low speed (40 Hz) motor operation and 14 (DI-3) for high speed (60 Hz) motor operation. See Table 12 and Fig. 28 (on page 21).

- For ACH550 VFDs the voltage is sourced from the VFD at its terminal 10 (+24 V). SAV speed inputs are received at terminals 14 (DI-2) for low speed (40 Hz) motor operation and 13 (DI-3) for high speed (60 Hz) motor operation. See Table 13 and Fig. 29 (on page 21).

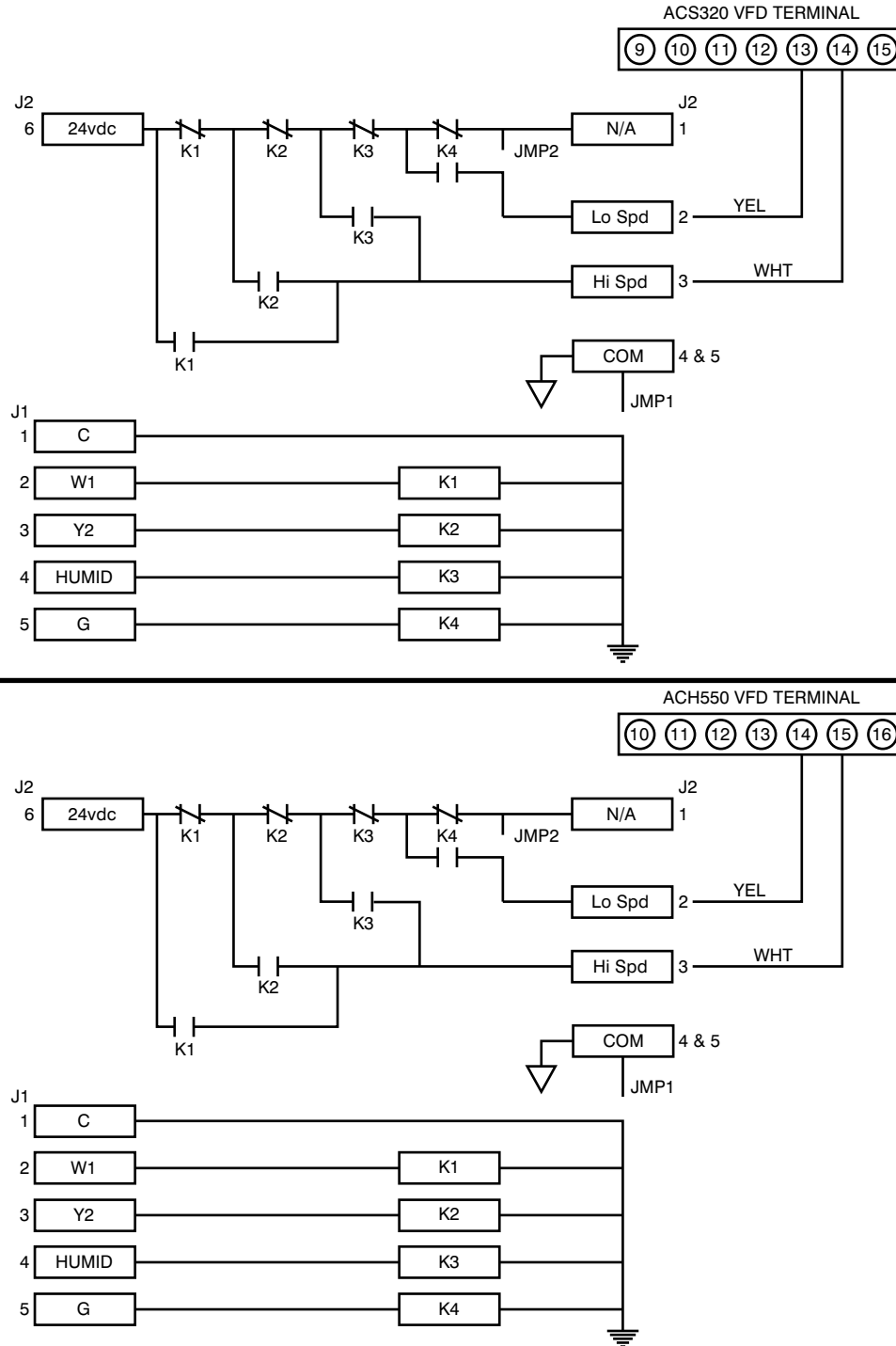
When neither input is present, the VFD will shut the fan motor off. There is no separate indoor fan contactor required in this application.

The VFD used in the SAV™ system has soft start capabilities to slowly ramp up the speeds, eliminating any high inrush of

air volume during speed changes. It also has internal over current protection for the fan motor.

### INDOOR FAN MOTOR

The indoor fan motors used with the VFD are specially manufactured for use with VFD power circuits. The motor winding insulation is specially formulated to resist breakdown due to voltage stress issues. The motor shaft includes grounding rings to prevent damage to bearings caused by grounding currents. Replace these motors with Factory Authorized Parts available from Replacement Components Division (RCD).



**Fig. 27 — Connection Schematic - Fan Speed Relay Board and VFD**



## VFD Fuses

Table 16 details the fuse requirement for the VFD installed in 48/50TC, 50TCQ, 48/50HC, and 50HCQ units. Table 17 details the fuse requirement for the VFD installed in 40RU units.

Check the control wiring diagram label on the specific unit in use for the fuse location.

**Table 16 — VFD Fuse Requirements, 48/50TC, 50TCQ, 48/50HC, and 50HCQ Units**

UNIT	HP	VOLTAGE	VFD	MOTOR	STANDARDIZED FUSE	FUSE P/N	HARNES WIRE GAUGE*
48/50TC07-14 50TCQ07-12 48/50HC07-12 50HCQ07-09	1.7	208/230	HK30WA523	HD56FR233	30A - CLASS CC KTK	HY10KB095	14
		460	HK30WA530	HD56FR463	15A - CLASS CC KTK	HY10KB092	14
		575	HK30WA360	HD56FR579	10A - CLASS CC KTK	HY10KB090	14
	2.4	208/230	HK30WA523	HD56FE653	30A - CLASS CC KTK	HY10KB095	14
		460	HK30WA530	HD56FE653	15A - CLASS CC KTK	HY10KB092	14
		575	HK30WA360	HD56FE577	10A - CLASS CC KTK	HY10KB090	14
	2.9	208/230	HK30WA523	HD58FE654	30A - CLASS CC KTK	HY10KB095	14
		460	HK30WA530	HD58FE654	15A - CLASS CC KTK	HY10KB092	14
	3.7	208/230	HK30WA523	HD60FE656, HD58FR236	30A - CLASS CC KTK	HY10KB095	14
		460	HK30WA534	HD60FE656, HD58FR236	20A - CLASS CC KTK	HY10KB093	14
		575	HK30WA361	HD58FE577	10A - CLASS CC KTK	HY10KB090	14
	4.9	208/230	HK30WA523	HD60FK658	30A - CLASS CC KTK	HY10KB095	14
		460	HK30WA532	HD60FK658	30A - CLASS CC KTK	HY10KB095	14
		575	HK30WA362	HD60FE576, HD60FL576	10A - CLASS CC KTK	HY10KB090	14
	48/50TC16 50TCQ14 48/50HC14 50HCQ12	2.9	208/230	HK30WA523	HD58FE654	30A - CLASS CC KTK	HY10KB300
460			HK30WA530	HD58FE654	15A - CLASS CC KTK	HY10KB151	14
575			HK30WA360	-	10A - CLASS CC KTK	HY10KB101	14
3.7		208/230	HK30WA523	HD60FE656, HD58FR236	30A - CLASS CC KTK	HY10KB300	14
		460	HK30WA534	HD60FE656, HD58FR236	20A - CLASS CC KTK	HY10KB200	14
		575	HK30WA361	HD58FE577	10A - CLASS CC KTK	HY10KB101	14
5		208/230	HK30WA524	HD60FK657, HD60FK659	30A - CLASS CC KTK	HY10KB300	14
		460	HK30WA532	HD60FK657, HD60FK659	30A - CLASS CC KTK	HY10KB300	14
		575	HK30WA362	HD60FE576, HD60FL576, HD60FK577	15A - CLASS CC KTK	HY10KB151	14
48/50TC17-30 50TCQ17-24 48/50HC17-28	2.9	208/230	HK30WA523	HD58FE654	30A - CLASS CC KTK	HY10KB300	10
		460	HK30WA530	HD58FE654	15A - CLASS CC KTK	HY10KB151	12
		575	HK30WA360	-	10A - CLASS CC KTK	HY10KB101	12
	3.7	208/230	HK30WA523	HD58FR236	30A - CLASS CC KTK	HY10KB300	10
		460	HK30WA534	HD60FE656	20A - CLASS CC KTK	HY10KB200	12
		575	HK30WA361	HD58FE577	10A - CLASS CC KTK	HY10KB101	12
	4.9	208/230	HK30WA523	HD60FK658	30A - CLASS CC KTK	HY10KB300	10
		460	HK30WA532	HD60FK658	30A - CLASS CC KTK	HY10KB300	12
		575	HK30WA362	HD60FE576, HD60FL576	15A - CLASS CC KTK	HY10KB151	12
	5	208/230	HK30WA524	HD60FK657, HD60FK659	60 - CLASS J, JKS	HY10JK060	8
		460	HK30WA532	HD60FK657, HD60FK659	30A - CLASS CC KTK	HY10KB300	12
		575	HK30WA362	HD60FE576, HD60FL576, HD60FK577	15A - CLASS CC KTK	HY10KB151	12
	7.5	208/230	HK30WA524	HD62FK654	60 - CLASS J, JKS	HY10JK060	8
		460	HK30WA532	HD62FK654	30A - CLASS CC KTK	HY10KB300	12
		575	HK30WA362	HD62FL576	15A - CLASS CC KTK	HY10KB151	12
10	208/230	HK30WA525	HD64FK654	60 - CLASS J, JKS	HY10JK060	8	
	460	HK30WA533	HD64FK654	30A - CLASS CC KTK	HY10KB300	12	
	575	HK30WA363	HD64FL576	15A - CLASS CC KTK	HY10KB151	12	

\*Harness wire gauge between control box and VFD.

**Table 17 — VFD Fuse Requirements, 40RU Units**

UNIT	HP	VOLTAGE	VFD	MOTOR	STANDARDIZED FUSE	FUSE P/N	HARNES WIRE GAUGE*
40RU	1.7	208/230	HK30WA523	HD56FR233	30A - CLASS CC KTK	HY10KB300	10
		460	HK30WA530	HD56FR463	15A - CLASS CC KTK	HY10KB151	10
		575	HK30WA360	HD56FR579	10A - CLASS CC KTK	HY10KB101	10
	2.4	208/230	HK30WA523	HD56FE653	30A - CLASS CC KTK	HY10KB300	10
		460	HK30WA530	HD56FE653	15A - CLASS CC KTK	HY10KB151	10
		575	HK30WA360	HD56FE577	10A - CLASS CC KTK	HY10KB101	10
	2.9	208/230	HK30WA523	HD58FE654	30A - CLASS CC KTK	HY10KB300	10
		460	HK30WA530	HD58FE654	30A - CLASS CC KTK	HY10KB300	10
	3.7	208/230	HK30WA523	HD58FR236	30A - CLASS CC KTK	HY10KB300	10
		208/230	HK30WA523	HD60FE656	30A - CLASS CC KTK	HY10KB300	10
		460	HK30WA534	HD58FR236	20A - CLASS CC KTK	HY10KB200	10
		460	HK30WA534	HD60FE656	20A - CLASS CC KTK	HY10KB200	10
		575	HK30WA361	HD58FE577	10A - CLASS CC KTK	HY10KB101	10
	5	208/230	HK30WA524	HD60FK659	30A - CLASS CC KTK	HY10KB300	10
		460	HK30WA532	HD60FK659	30A - CLASS CC KTK	HY10KB300	10
		575	HK30WA362	HD60FK577	15A - CLASS CC KTK	HY10KB151	10
	7.5	208/230	HK30WA523	HD62FK654	60A - CLASS J	HY10JK060	10
		460	HK30WA532	HD62FK654	30A - CLASS CC KTK	HY10KB300	10
		575	HK30WA362	HD62FL576	15A - CLASS CC KTK	HY10KB151	10
	10	208/230	HK30WA525	HD64FK654	60A - CLASS J	HY10JK060	10
		460	HK30WA533	HD64FK654	30A - CLASS CC KTK	HY10KB300	10
		575	HK30WA363	HD64FL576	15A - CLASS CC KTK	HY10KB151	10

\*Harness wire gauge between control box and VFD.

### Control and Power Wiring Diagrams

See Fig. 31-37 for examples of typical unit wiring diagrams. For details pertaining to a specific unit, see the control and power wiring diagram labels on the unit.

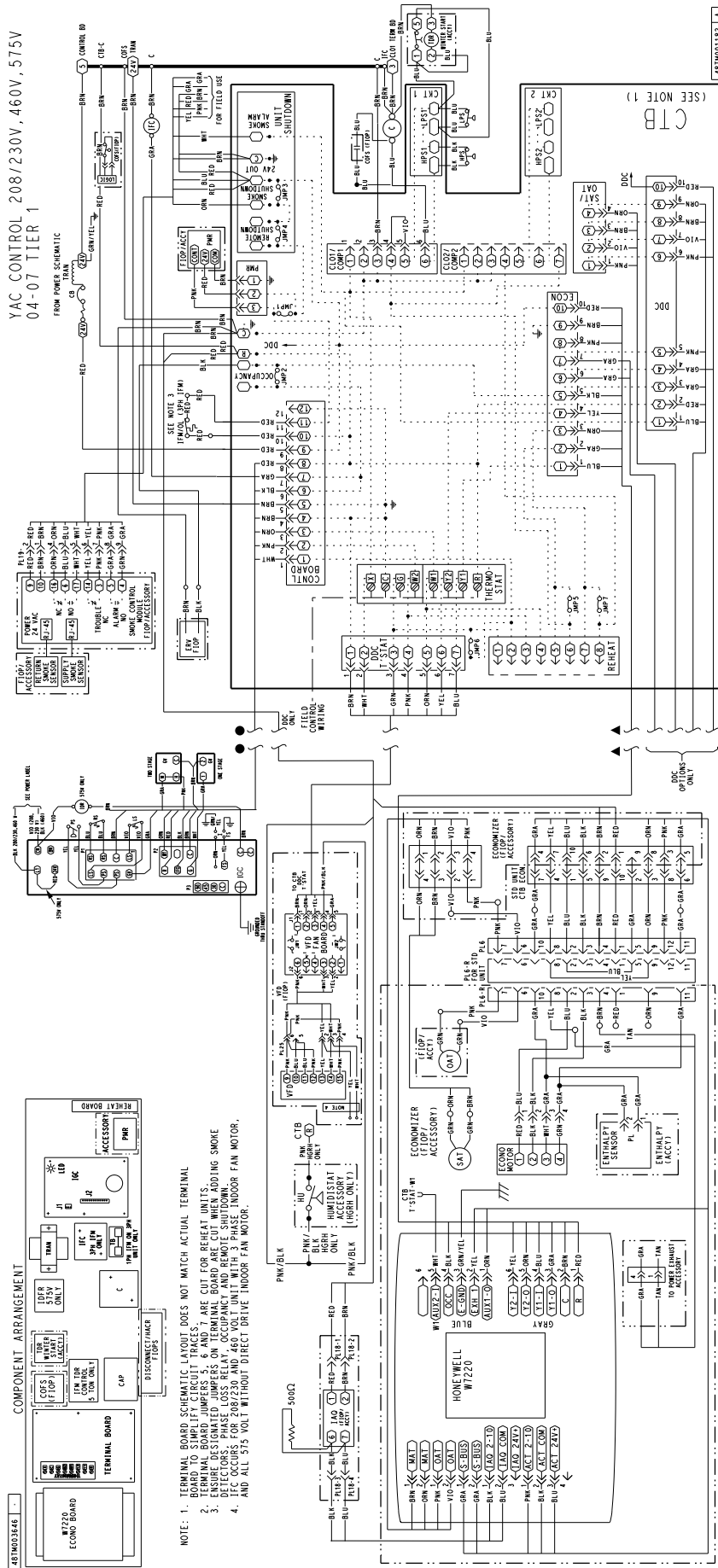


Fig. 31 — Typical Wiring Diagram - Single Package Rooftop Unit (48TC\*07 with ACS320 VFD shown)



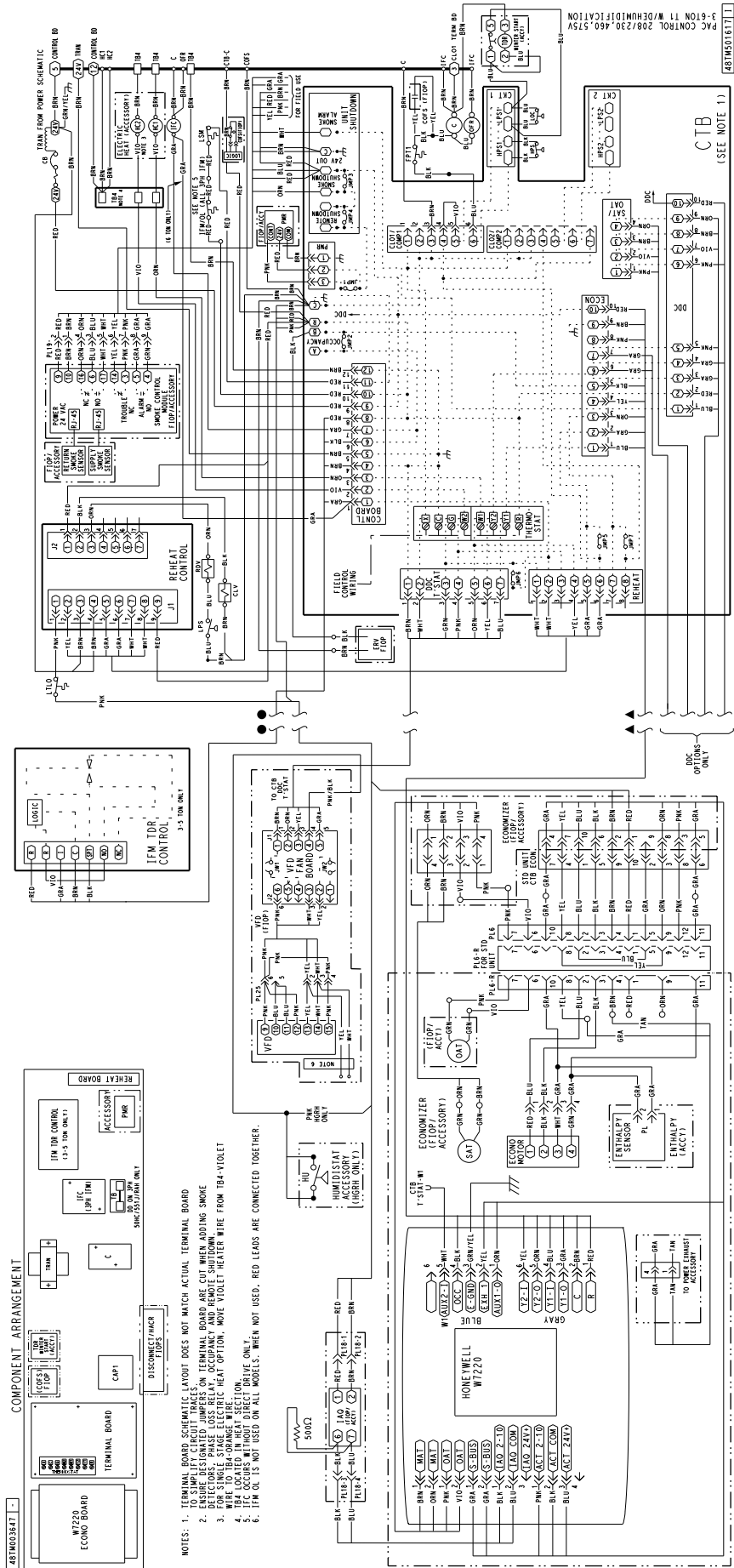
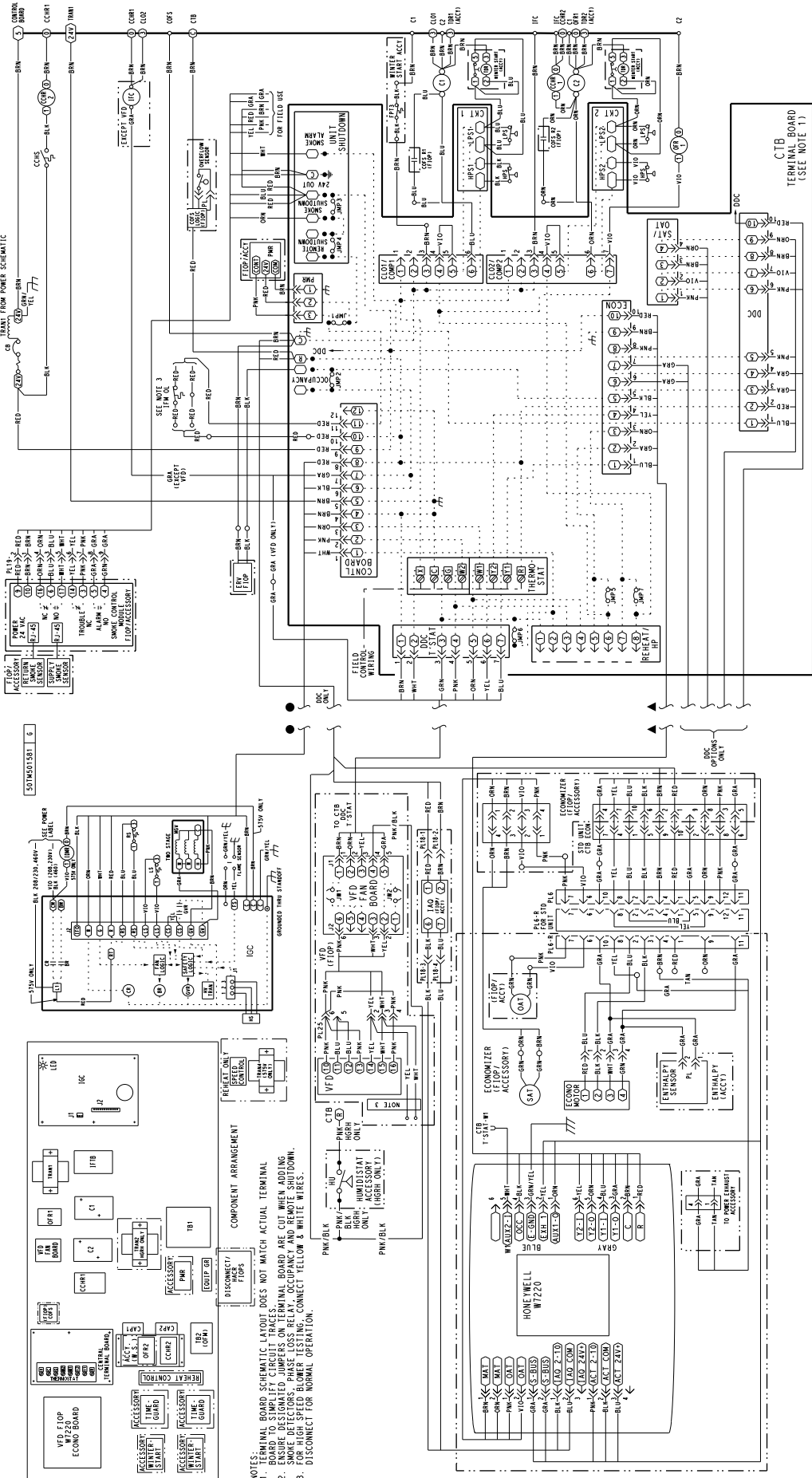
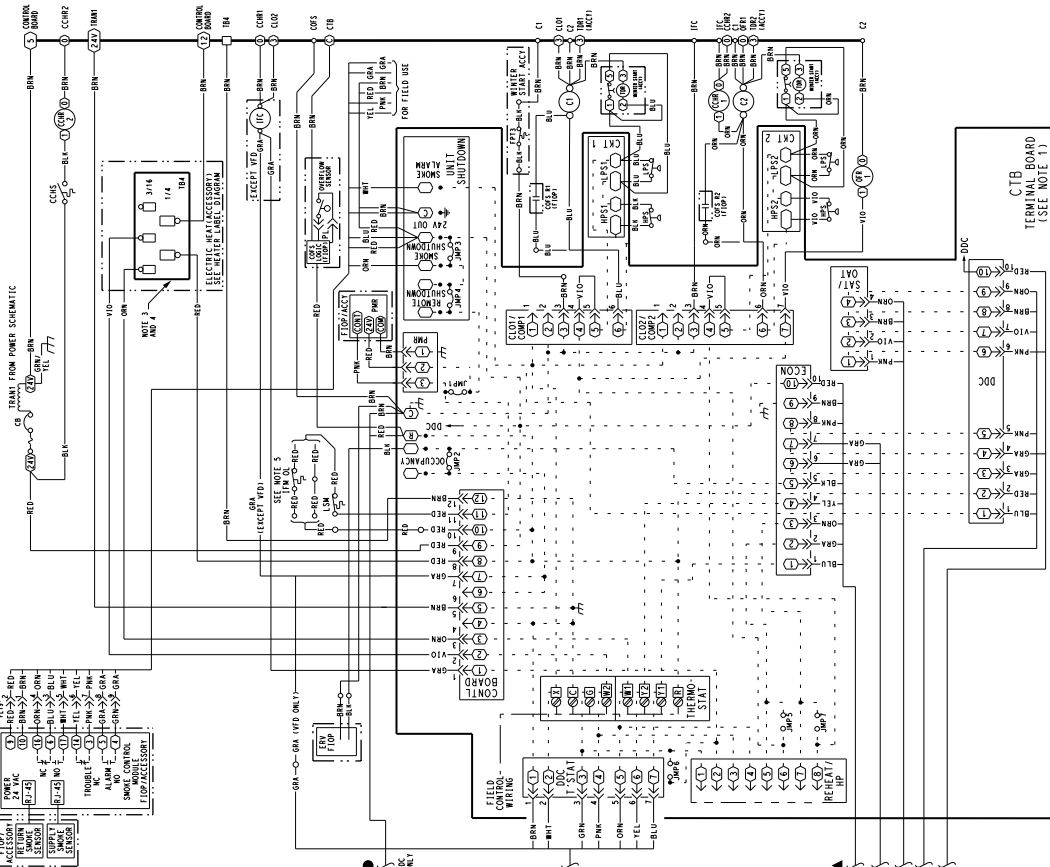


Fig. 32 — Typical Wiring Diagram - Single Package Rooftop Unit (50TC\*07 with ACS320 VFD shown)

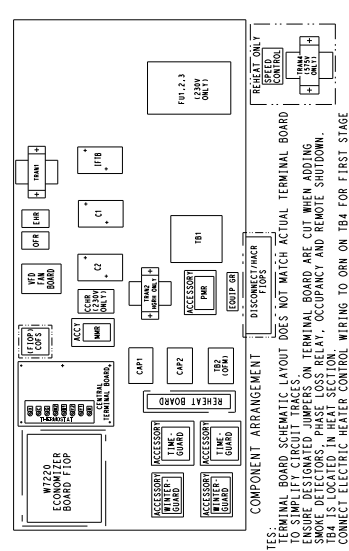
MID TIER YAC CONTROL 208/230V, 460V, 575V  
3 OFM DUAL COMPRESSOR



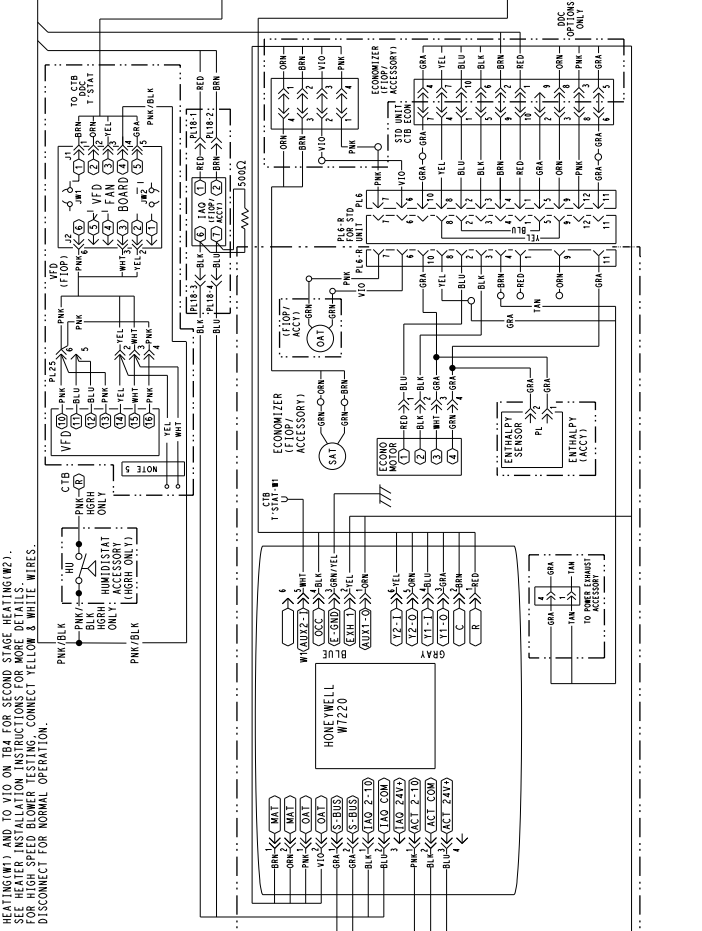
PAC CONTROL 208/230V 460V 575V  
3 OFM DUAL COMPRESSOR



501M50141 B

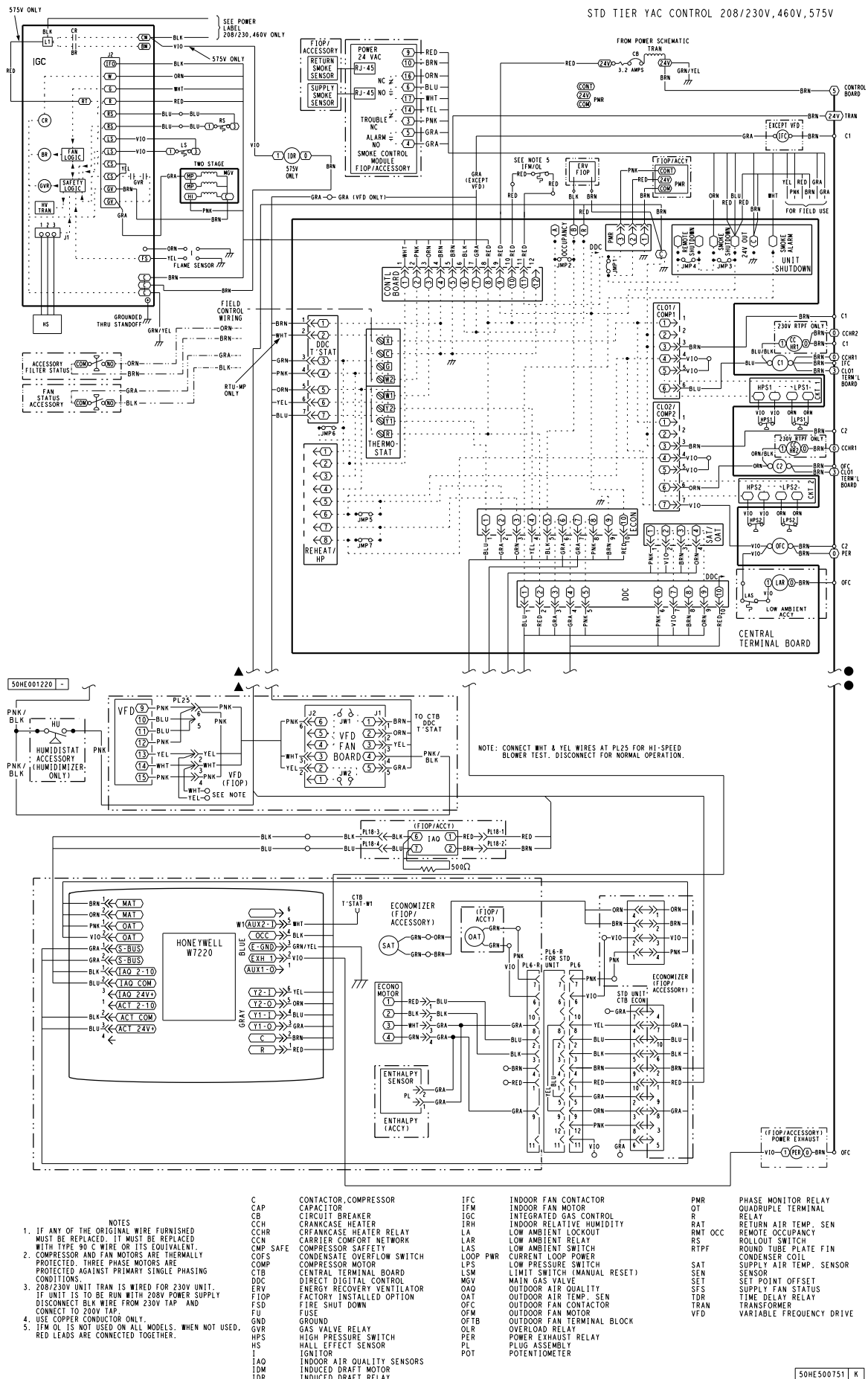


- NOTES:
1. TERMINAL BOARD SCHEMATIC LAYOUT DOES NOT MATCH ACTUAL TERMINAL BOARD TO SIMPLIFY CIRCUIT TRACES.
  2. ENSURE DESIGNATED JUMPERS ON TERMINAL BOARD ARE ON WHEN ADDING OR REMOVING WIRING TO RELAY, OCCUPANCY AND RESET SHUTDOWN.
  3. TBA IS LOCATED IN HEAT SECTION.
  4. CONNECT ELECTRIC HEATER CONTROL WIRING TO ORN ON TBA FOR FIRST STAGE HEATING. WIRING TO OTHER STAGES OF SECOND WIRE BE HEATING (HW2).
  5. FOR HIGH SPEED BLOWER TESTING, CONNECT YELLOW & WHITE WIRES. DISCONNECT FOR NORMAL OPERATION.



501M501064 K

Fig. 34 — Typical Wiring Diagram - Single Package Rooftop Unit (50HC\*14 with ACH550 VFD shown)



- NOTES**
1. IF ANY OF THE ORIGINAL WIRE FURNISHED MUST BE REPLACED, IT MUST BE REPLACED WITH TYPE 90 C WIRE OR ITS EQUIVALENT.
  2. COMPRESSOR AND FAN MOTORS ARE THERMALLY PROTECTED. THREE PHASE MOTORS ARE PROTECTED AGAINST PRIMARY SINGLE PHASING CONDITIONS.
  3. 208/230V UNIT TRN IS WIRED FOR 230V UNIT. IF UNIT IS TO BE RUN WITH 200V POWER SUPPLY DISCONNECT BLK WIRE FROM 230V TAP AND CONNECT TO 200V TAP.
  4. USE COPPER CONDUCTOR ONLY.
  5. IFM OL IS NOT USED ON ALL MODELS. WHEN NOT USED, RED LEADS ARE CONNECTED TOGETHER.

C	CONTACTOR, COMPRESSOR	IFC	INDOOR FAN CONTACTOR	PMR	PHASE MONITOR RELAY
CAP	CAPACITOR	IFM	INDOOR FAN MOTOR	QT	QUADRUPLE TERMINAL
CB	CIRCUIT BREAKER	IGC	INTEGRATED GAS CONTROL	R	RELAY
CCH	CRANKCASE HEATER	IRH	INDOOR RELATIVE HUMIDITY	RAT	RETURN AIR TEMP. SEN
CCHR	CRANKCASE HEATER RELAY	LA	LOW AMBIENT LOCKOUT	RMT OCC	REMOTE OCCUPANCY
CCN	CARRIER COMFORT NETWORK	LAR	LOW AMBIENT RELAY	RS	ROLL-OUT SWITCH
CCP	COMPRESSOR SAFETY	LAS	LOW AMBIENT SWITCH	RTPF	ROUND TUBE PLATE FIN
CCS	CONDENSATE OVERFLOW SWITCH	LC	CURRENT LOOP POWER	SC	CONDENSER COIL
CCF	COMPRESSOR MOTOR	LPS	LOW PRESSURE SWITCH	SAT	SUPPLY AIR TEMP. SENSOR
CTB	CENTRAL TERMINAL BOARD	LSM	LIMIT SWITCH (MANUAL RESET)	SEN	SENSOR
DDC	DIRECT DIGITAL CONTROL	MGV	MAIN GAS VALVE	SET	SET POINT OFFSET
ERV	ENERGY RECOVERY VENTILATOR	OAO	OUTDOOR AIR QUALITY	SFS	SUPPLY FAN STATUS
FIOF	FACTORY INSTALLED OPTION	OAT	OUTDOOR AIR TEMP. SEN	TDR	TIME DELAY RELAY
FSD	FIRE SHUT DOWN	OFC	OUTDOOR FAN CONTACTOR	TRN	TRANSFORMER
FU	FUSE	OFM	OUTDOOR FAN MOTOR	VFD	VARIABLE FREQUENCY DRIVE
GND	GROUND	OFTB	OUTDOOR FAN TERMINAL BLOCK		
GVR	GAS VALVE RELAY	OL	OVERLOAD RELAY		
HPS	HIGH PRESSURE SWITCH	PER	POWER EXHAUST RELAY		
HS	HALL EFFECT SENSOR	PL	PLUG ASSEMBLY		
I	IGNITOR	POT	POTENTIOMETER		
IAQ	INDOOR AIR QUALITY SENSORS				
IDM	INDUCED DRAFT MOTOR				
IDR	INDUCED DRAFT RELAY				

**Fig. 35 — Typical Wiring Diagram - Single Package Rooftop Unit (48TC\*17-30 with ACS320 VFD shown)**

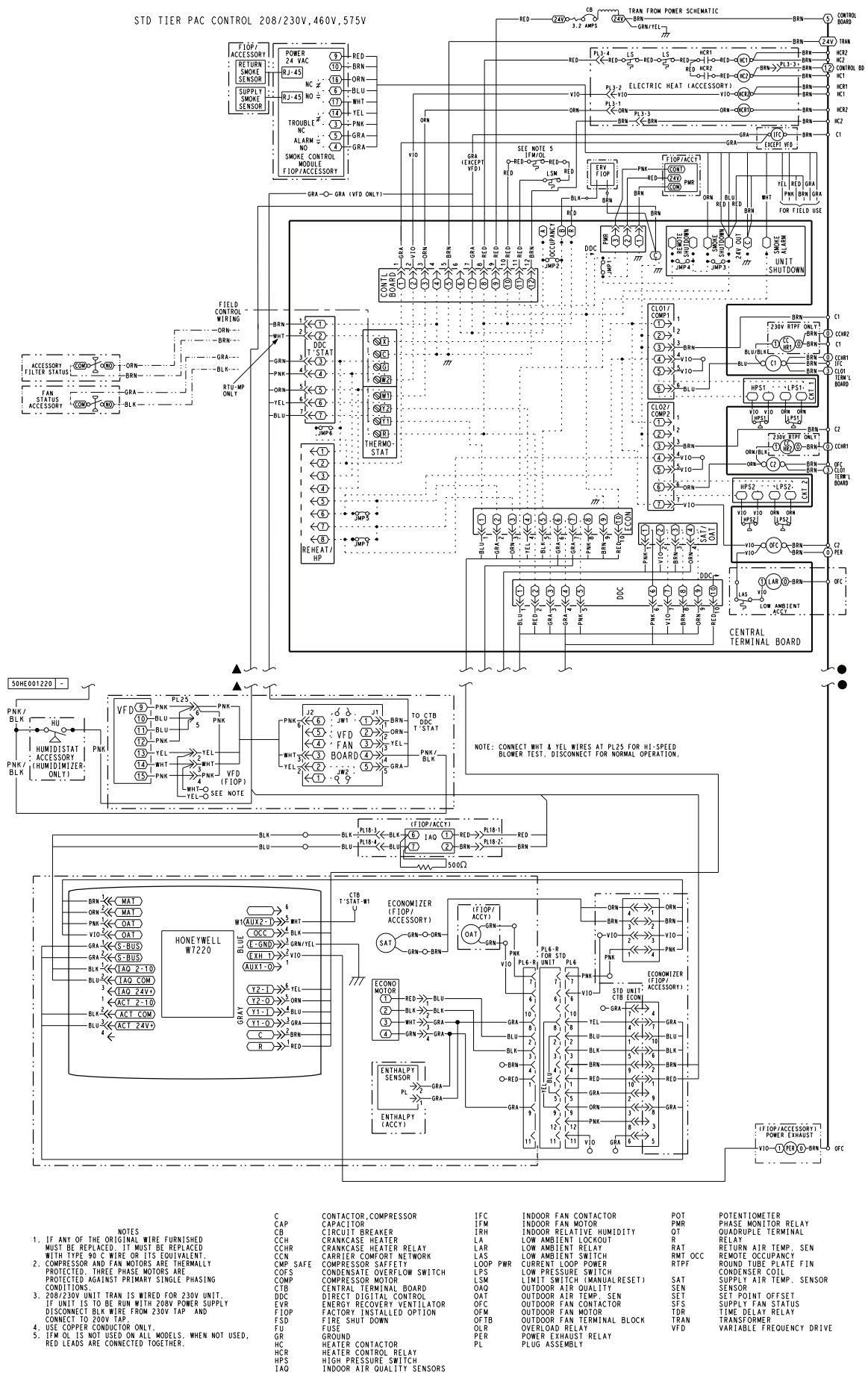
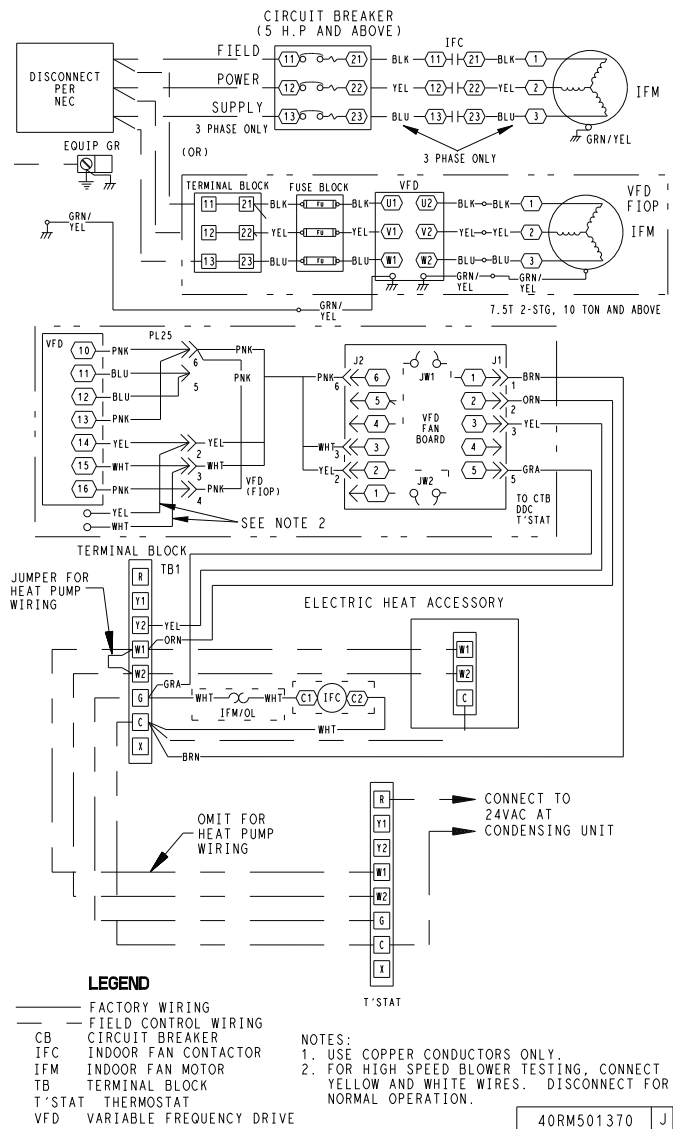


Fig. 36 — Typical Wiring Diagram - Single Package Rooftop Unit (50TC\*17-30 with ACS320 VFD shown)



**Fig. 37 — Typical Wiring Diagram - Split System Air-Handling Unit (40RU with ACH550 VFD shown)**

## VFD ALARMS AND FAULTS TROUBLESHOOTING

The VFD has two LEDs on its front panel that indicate VFD operating status. These LEDs are GREEN and RED.

- GREEN LED ON STEADY: Power ON to VFD
- GREEN LED FLASHING: Alarm condition detected
- RED LED ON (Steady or Flashing): Fault condition detected

### Alarms

Alarms are advisory in nature. These indicate a problem has been detected by the VFD's diagnostics but this problem will not require that the VFD and its motor be shut down. Typical fault condition on the SAV™ application might be loose connections at the VFD terminal board or damaged conductors between the Fan Speed Board connector J2 and the VFD terminal strip. See Table I in Appendix A for a full list.

#### CLEAR THE ALARM LED

Shut off power to the VFD for five minutes. Restore power and recheck the GREEN LED. If this LED is still flashing, connect the accessory remote display keypad kit and follow the troubleshooting instructions in Appendix A, page 52.

### Faults

A fault is a significant internal situation for the VFD or its motor. If the motor was running when the fault was detected, it was shutdown. See Table H in Appendix A for a full list of Faults, display codes and recommended actions. Connect the accessory remote display keypad kit and follow the troubleshooting instructions in Appendix A.

#### CLEAR THE FAULT LED

Shut off power to the VFD for five minutes. Restore power and recheck the RED LED.

### VFD Maintenance

If installed in an appropriate environment, the VFD requires very little maintenance.

Table 18 lists the routine maintenance intervals recommended by Carrier.

**Table 18 — Maintenance Intervals**

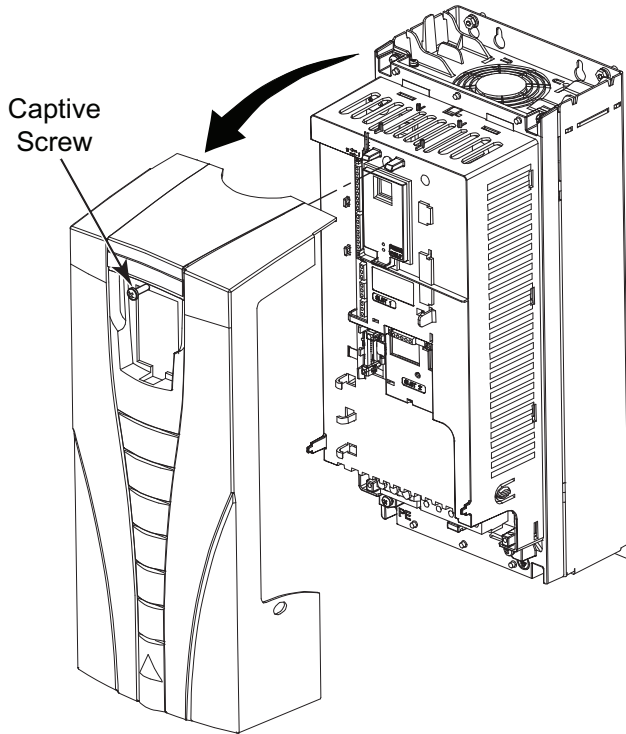
MAINTENANCE	INTERVAL
Heat sink temperature check and cleaning	Every 6 to 12 months (depending on the dustiness of the environment)
HVAC control panel battery change	Every ten years

## Heat Sink Cleaning

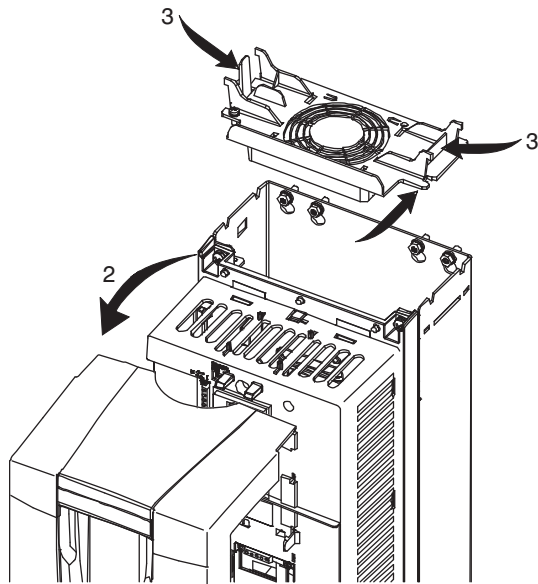
The heat sink fins accumulate dust from the cooling air. In a normal environment check the heat sink annually, in a dusty environment check more often.

Use the following procedure to clean the heat sink on AHC550 VFDs:

1. Turn off and lock out unit power.
2. Remove the drive cover (see Fig. 38).
3. Press together the retaining clips on the top cover and lift (see Fig. 39).



**Fig. 38 — Remove AHC550 VFD Front Cover**

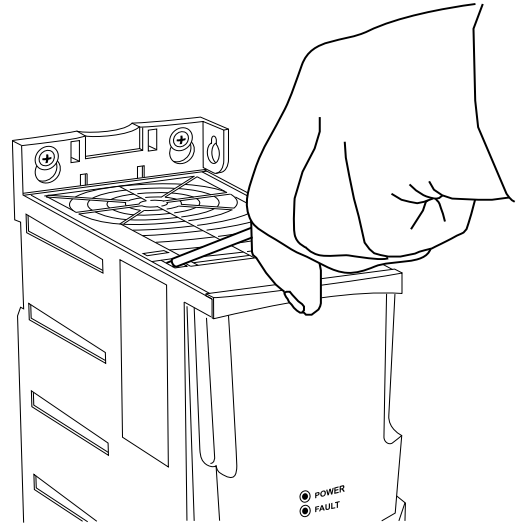


**Fig. 39 — Remove Top Cover on AHC550 VFD**

4. Blow clean compressed air (not humid) from bottom to top while simultaneously using a vacuum cleaner at the air outlet to trap the dust.
5. Replace the cooling fan.
6. Replace the drive cover.
7. Restore power.

Use the following procedure to clean the heat sink on ACS320 VFDs:

1. Turn off and lock out unit power.
2. Insert a small straight blade screwdriver into the slot and press in to release the top cover as shown in Fig. 40.



**Fig. 40 — Remove Top Cover on ACS320 VFD**

3. Blow clean compressed air (not humid) from top of ACS320 while simultaneously using a vacuum cleaner at the base to trap the dust.
4. Replace the top cover.
5. Restore power.

## Bypass the VFD

The following procedures detail how to bypass (disconnect) the factory installed VFD. See Fig. 41 and 42 for simplified schematics.

To bypass the VFD on the following units – 48/50TC 07-14, 50TCQ 07-12, 48/50HC 07-12, 50HCQ 08-09, and 40RU:

1. Turn off and lock out unit power.
2. Disconnect the connectors linking the fuse to the control box and to the VFD.
3. Disconnect the connector between the VFD and the indoor fan motor.
4. Disconnect the ground wires at the base of the VFD.
5. Remove the VFD, if required.
6. Connect the lead from the control box to the lead from the indoor fan motor.
7. Connect the ground wire from the indoor fan motor to the fan deck.
8. Restore power.

To bypass the VFD on the following units – 48/50TC 16-30, 50TCQ 14-24, and 48/50HC 17-28:

1. Turn off and lock out unit power.
2. Disconnect the connection between the control box and the VFD.
3. Disconnect the connection between the indoor fan motor and the VFD.
4. Disconnect the ground wires at the base of the VFD.
5. Remove the VFD, if required.
6. Connect the lead from the control box to the lead from the indoor fan motor.
7. Attach the ground wire leading from the fan motor to the fan deck.
8. Restore power.

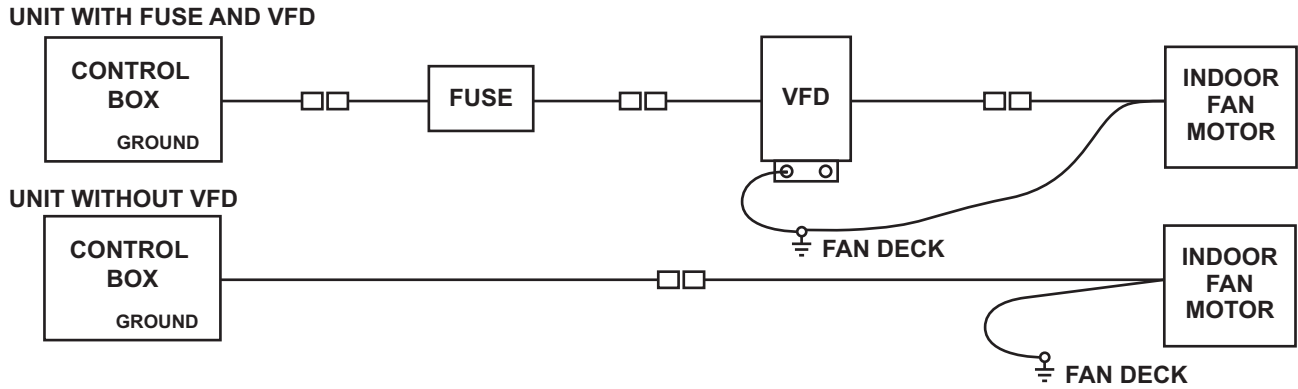


Fig. 41 — To Bypass the VFD on 48/50TC 07-14, 50TCQ 07-12, 48/50HC 07-12, 50HCQ 08-09, and 40RU Units

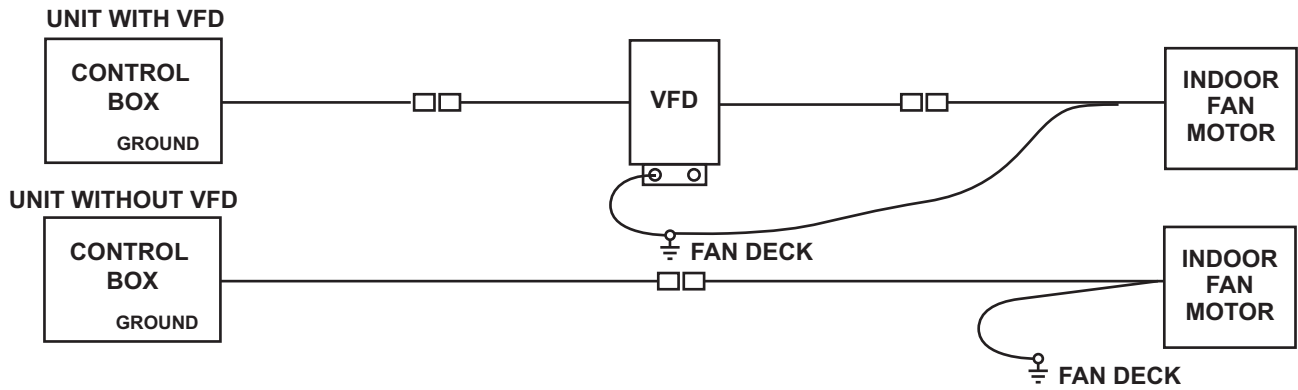


Fig. 42 — To Bypass the VFD on 48/50TC 16-30, 50TCQ 14-24, and 48/50HC 17-28 Units

### BASIC VFD PARAMETERS

See Table 19 for basic VFD parameters organized by lookup variable for 48/50 units. See Tables 20 and 21 for basic VFD parameters for 40RU units.



**Table 19 — Basic VFD Parameters, 48/50 Units**

LOOKUP VARIABLE	REFERENCE NUMBER ACS320	MOTOR PART NUMBER	VFD PART NUMBER	REPLACEMENT COMPONENT PART NUMBER	DRIVE HP	DESC	CONTROLS
48TM003773-DATA	48TM003773	HD56FR233	HK30WA523	HK30WA506	3	SRT 1.7 HP 230V	EM
48TM003776-DATA	48TM003776	HD56FR463	HK30WA530	HK30WA512	3	SRT 1.7 HP 460V	EM
48TM003772-DATA	48TM003772	HD56FE653	HK30WA523	HK30WA506	3	SRT 2.4 HP 230V	EM
48TM003784-DATA	48TM003784	HD56FE653	HK30WA530	HK30WA512	3	SRT 2.4 HP 460V	EM
48TM003782-DATA	48TM003782	HD58FE654	HK30WA523	HK30WA506	3	SRT 2.9 HP 230V	EM
48TM003777-DATA	48TM003777	HD58FE654	HK30WA530	HK30WA512	3	SRT 2.9 HP 460V	EM
48TM003774-DATA	48TM003774	HD60FE656	HK30WA523	HK30WA506	3	SRT 3.7 HP 230V	EM
48TM003783-DATA	48TM003783	HD60FE656	HK30WA534	HK30WA517	5	SRT 3.7 HP 460V	EM
48TM003775-DATA	48TM003775	HD60FK658	HK30WA523	HK30WA506	3	SRT 5.3 HP 230V	EM
48TM003778-DATA	48TM003778	HD60FK658	HK30WA532	HK30WA514	7.5	SRT 5.3 HP 460V	EM
50TM001206-DATA	50TM001206	HD58FE654	HK30WA523	HK30WA506	3	STR 2.9 HP 230V	EM
50TM001211-DATA	50TM001211	HD58FE654	HK30WA530	HK30WA512	3	STR 2.9 HP 460V	EM
50TM001209-DATA	50TM001209	HD60FE656	HK30WA523	HK30WA506	3	STR 3.7 HP 230V	EM
50TM001210-DATA	50TM001210	HD60FE656	HK30WA534	HK30WA517	5	STR 3.7 HP 460V	EM
50TM001208-DATA	50TM001208	HD60FK657	HK30WA524	HK30WA507	7.5	STR 5.0 HP 230V	EM
50TM001212-DATA	50TM001212	HD60FK657	HK30WA532	HK30WA514	7.5	STR 5.0 HP 460V	EM
50HE001312-DATA	50HE001312	HD58FE654	HK30WA523	HK30WA506	3	MRT 2.9 HP 230V	EM
50HE001316-DATA	50HE001316	HD58FE654	HK30WA530	HK30WA512	3	MRT 2.9 HP 460V	EM
50HE001313-DATA	50HE001313	HD60FE656	HK30WA523	HK30WA506	3	MRT 3.7 HP 230V	EM
50HE001317-DATA	50HE001317	HD60FE656	HK30WA534	HK30WA517	5	MRT 3.7 HP 460V	EM
50HE001314-DATA	50HE001314	HD60FK657	HK30WA524	HK30WA507	7.5	MRT 5.0 HP 230V	EM
50HE001318-DATA	50HE001318	HD60FK657	HK30WA532	HK30WA514	7.5	MRT 5.0 HP 460V	EM
50HE001315-DATA	50HE001315	HD62FK654	HK30WA524	HK30WA507	7.5	MRT 7.5 HP 230V	EM
50HE001319-DATA	50HE001319	HD62FK654	HK30WA532	HK30WA514	7.5	MRT 7.5 HP 460V	EM
50HE001320-DATA	50HE001320	HD60FK658	HK30WA523	HK30WA506	3	MRT 5.3 HP 230V	EM
50HE001321-DATA	50HE001321	HD60FK658	HK30WA532	HK30WA514	7.5	MRT 5.3 HP 460V	EM
50HE402586-DATA	50HE402586	HD64FK654	HK30WA525	HK30WA508	10	MRT 10.0 HP 230V	EM
50HE402591-DATA	50HE402591	HD64FK654	HK30WA533	HK30WA515	10	MRT 10.0 HP 460V	EM

**Table 19 — Basic VFD Parameters, 48/50 Units (cont)**

LOOKUP VARIABLE	VFD PARAMETER DESCRIPTION/ID							
	VOLTAGE	N. AMPS	MOTOR NOM. FREQ.	N. RPM	N. HP	EXT1 COMMANDS	EXT1/EXT2 COMMANDS	REF1 SELECT
	9905	9906	9907	9908	9909	1001	1102	1103
48TM003773-DATA	230	5.6	60Hz	1725	1.7	—	—	—
48TM003776-DATA	460	2.9	60Hz	1725	1.7	—	—	—
48TM003772-DATA	230	6.8	60Hz	1725	2.4	—	—	—
48TM003784-DATA	460	3.4	60Hz	1725	2.4	—	—	—
48TM003782-DATA	230	7.8	60Hz	1725	2.9	—	—	—
48TM003777-DATA	460	3.8	60Hz	1725	2.9	—	—	—
48TM003774-DATA	230	9.8	60Hz	1725	3.7	—	—	—
48TM003783-DATA	460	4.9	60Hz	1725	3.7	—	—	—
48TM003775-DATA	230	12.7	60Hz	1740	5.3	—	—	—
48TM003778-DATA	460	6.4	60Hz	1740	5.3	—	—	—
50TM001206-DATA	230	7.8	60Hz	1725	2.9	—	—	—
50TM001211-DATA	460	3.8	60Hz	1725	2.9	—	—	—
50TM001209-DATA	230	9.8	60Hz	1725	3.7	—	—	—
50TM001210-DATA	460	4.9	60Hz	1725	3.7	—	—	—
50TM001208-DATA	230	17.1	60Hz	1760	5	—	—	—
50TM001212-DATA	460	8.6	60Hz	1760	5	—	—	—
50HE001312-DATA	230	7.8	60Hz	1725	2.9	—	—	—
50HE001316-DATA	460	3.8	60Hz	1725	2.9	—	—	—
50HE001313-DATA	230	9.8	60Hz	1725	3.7	—	—	—
50HE001317-DATA	460	4.9	60Hz	1725	3.7	—	—	—
50HE001314-DATA	230	20.4	60Hz	1760	5	—	—	—
50HE001318-DATA	460	10.2	60Hz	1760	5	—	—	—
50HE001315-DATA	230	28.5	60Hz	1760	7.5	—	—	—
50HE001319-DATA	460	13.7	60Hz	1760	7.5	—	—	—
50HE001320-DATA	230	12.7	60Hz	1740	5.3	—	—	—
50HE001321-DATA	460	6.4	60Hz	1740	5.3	—	—	—
50HE402586-DATA	230	30.4	60Hz	1755	10	—	—	—
50HE402591-DATA	460	15.2	60Hz	1755	10	—	—	—

— — Factory default setting. See label.

**Table 19 — Basic VFD Parameters, 48/50 Units (cont)**

LOOKUP VARIABLE	VFD PARAMETER DESCRIPTION/ID							
	CONST SPEED SELECT	CONST SPEED 1	CONST SPEED 2	CONST SPEED 3	CONST SPEED 4	RELAY OUT 1	RELAY OUT 3	A01 CONTENT SET
	1201	1202	1203	1204	1205	1401	1403	1501
48TM003773-DATA	DI 2,3	40Hz	60Hz	60Hz	—	16 FLT/Alarm	—	—
48TM003776-DATA	DI 2,3	40Hz	60Hz	60Hz	—	16 FLT/Alarm	—	—
48TM003772-DATA	DI 2,3	40Hz	60Hz	60Hz	—	16 FLT/Alarm	—	—
48TM003784-DATA	DI 2,3	40Hz	60Hz	60Hz	—	16 FLT/Alarm	—	—
48TM003782-DATA	DI 2,3	40Hz	60Hz	60Hz	—	16 FLT/Alarm	—	—
48TM003777-DATA	DI 2,3	40Hz	60Hz	60Hz	—	16 FLT/Alarm	—	—
48TM003774-DATA	DI 2,3	40Hz	60Hz	60Hz	—	16 FLT/Alarm	—	—
48TM003783-DATA	DI 2,3	40Hz	60Hz	60Hz	—	16 FLT/Alarm	—	—
48TM003775-DATA	DI 2,3	40Hz	60Hz	60Hz	—	16 FLT/Alarm	—	—
48TM003778-DATA	DI 2,3	40Hz	60Hz	60Hz	—	16 FLT/Alarm	—	—
50TM001206-DATA	DI 2,3	40Hz	60Hz	60Hz	—	16 FLT/Alarm	—	—
50TM001211-DATA	DI 2,3	40Hz	60Hz	60Hz	—	16 FLT/Alarm	—	—
50TM001209-DATA	DI 2,3	40Hz	60Hz	60Hz	—	16 FLT/Alarm	—	—
50TM001210-DATA	DI 2,3	40Hz	60Hz	60Hz	—	16 FLT/Alarm	—	—
50TM001208-DATA	DI 2,3	40Hz	60Hz	60Hz	—	16 FLT/Alarm	—	—
50TM001212-DATA	DI 2,3	40Hz	60Hz	60Hz	—	16 FLT/Alarm	—	—
50HE001312-DATA	DI 2,3	40Hz	60Hz	60Hz	—	16 FLT/Alarm	—	—
50HE001316-DATA	DI 2,3	40Hz	60Hz	60Hz	—	16 FLT/Alarm	—	—
50HE001313-DATA	DI 2,3	40Hz	60Hz	60Hz	—	16 FLT/Alarm	—	—
50HE001317-DATA	DI 2,3	40Hz	60Hz	60Hz	—	16 FLT/Alarm	—	—
50HE001314-DATA	DI 2,3	40Hz	60Hz	60Hz	—	16 FLT/Alarm	—	—
50HE001318-DATA	DI 2,3	40Hz	60Hz	60Hz	—	16 FLT/Alarm	—	—
50HE001315-DATA	DI 2,3	40Hz	60Hz	60Hz	—	16 FLT/Alarm	—	—
50HE001319-DATA	DI 2,3	40Hz	60Hz	60Hz	—	16 FLT/Alarm	—	—
50HE001320-DATA	DI 2,3	40Hz	60Hz	60Hz	—	16 FLT/Alarm	—	—
50HE001321-DATA	DI 2,3	40Hz	60Hz	60Hz	—	16 FLT/Alarm	—	—
50HE402586-DATA	DI 2,3	40Hz	60Hz	60Hz	—	16 FLT/Alarm	—	—
50HE402591-DATA	DI 2,3	40Hz	60Hz	60Hz	—	16 FLT/Alarm	—	—

**Table 19 — Basic VFD Parameters, 48/50 Units (cont)**

LOOKUP VARIABLE	VFD PARAMETER DESCRIPTION/ID							
	PARAMETER VIEW	MAX AMPS	MIN FREQ	MAX FREQ	SWITCH FREQ	START FCN	STOP FCN	ACCEL/ DECEL
	1611	2003	2007	2008	2606	2101	2102	2201
48TM003773-DATA	3	5.6	0Hz	60Hz	4kHz	Auto	(1) Coast	Not Sel
48TM003776-DATA	3	2.9	0Hz	60Hz	4kHz	Auto	(1) Coast	Not Sel
48TM003772-DATA	3	6.8	0Hz	60Hz	4kHz	Auto	(1) Coast	Not Sel
48TM003784-DATA	3	3.4	0Hz	60Hz	4kHz	Auto	(1) Coast	Not Sel
48TM003782-DATA	3	7.8	0Hz	60Hz	4kHz	Auto	(1) Coast	Not Sel
48TM003777-DATA	3	3.8	0Hz	60Hz	4kHz	Auto	(1) Coast	Not Sel
48TM003774-DATA	3	9.8	0Hz	60Hz	4kHz	Auto	(1) Coast	Not Sel
48TM003783-DATA	3	4.9	0Hz	60Hz	4kHz	Auto	(1) Coast	Not Sel
48TM003775-DATA	3	12.7	0Hz	60Hz	4kHz	Auto	(1) Coast	Not Sel
48TM003778-DATA	3	6.4	0Hz	60Hz	4kHz	Auto	(1) Coast	Not Sel
50TM001206-DATA	3	7.8	0Hz	60Hz	4kHz	Auto	(1) Coast	Not Sel
50TM001211-DATA	3	3.8	0Hz	60Hz	4kHz	Auto	(1) Coast	Not Sel
50TM001209-DATA	3	9.8	0Hz	60Hz	4kHz	Auto	(1) Coast	Not Sel
50TM001210-DATA	3	4.9	0Hz	60Hz	4kHz	Auto	(1) Coast	Not Sel
50TM001208-DATA	3	17.1	0Hz	60Hz	4kHz	Auto	(1) Coast	Not Sel
50TM001212-DATA	3	8.6	0Hz	60Hz	4kHz	Auto	(1) Coast	Not Sel
50HE001312-DATA	3	7.8	0Hz	60Hz	4kHz	Auto	(1) Coast	Not Sel
50HE001316-DATA	3	3.8	0Hz	60Hz	4kHz	Auto	(1) Coast	Not Sel
50HE001313-DATA	3	9.8	0Hz	60Hz	4kHz	Auto	(1) Coast	Not Sel
50HE001317-DATA	3	4.9	0Hz	60Hz	4kHz	Auto	(1) Coast	Not Sel
50HE001314-DATA	3	20.4	0Hz	60Hz	4kHz	Auto	(1) Coast	Not Sel
50HE001318-DATA	3	10.2	0Hz	60Hz	4kHz	Auto	(1) Coast	Not Sel
50HE001315-DATA	3	28.5	0Hz	60Hz	4kHz	Auto	(1) Coast	Not Sel
50HE001319-DATA	3	13.7	0Hz	60Hz	4kHz	Auto	(1) Coast	Not Sel
50HE001320-DATA	3	12.7	0Hz	60Hz	4kHz	Auto	(1) Coast	Not Sel
50HE001321-DATA	3	6.4	0Hz	60Hz	4kHz	Auto	(1) Coast	Not Sel
50HE402586-DATA	3	30.4	0Hz	60Hz	4kHz	Auto	(1) Coast	Not Sel
50HE402591-DATA	3	15.2	0Hz	60Hz	4kHz	Auto	(1) Coast	Not Sel

— — Factory default setting. See label.

**Table 19 — Basic VFD Parameters, 48/50 Units (cont)**

LOOKUP VARIABLE	VFD PARAMETER DESCRIPTION/ID							
	ACCEL	DECEL	IR COMP VOLT	FBA TYPE	STATION ID	BAUD RATE	PARITY	EFB PROTOCOL ID
	2202	2203	2603	5101	5201	5202	5203	5301
48TM003773-DATA	30s	30s	0	—	—	—	—	—
48TM003776-DATA	30s	30s	0	—	—	—	—	—
48TM003772-DATA	30s	30s	0	—	—	—	—	—
48TM003784-DATA	30s	30s	0	—	—	—	—	—
48TM003782-DATA	30s	30s	0	—	—	—	—	—
48TM003777-DATA	30s	30s	0	—	—	—	—	—
48TM003774-DATA	30s	30s	0	—	—	—	—	—
48TM003783-DATA	30s	30s	0	—	—	—	—	—
48TM003775-DATA	30s	30s	0	—	—	—	—	—
48TM003778-DATA	30s	30s	0	—	—	—	—	—
50TM001206-DATA	30s	30s	0	—	—	—	—	—
50TM001211-DATA	30s	30s	0	—	—	—	—	—
50TM001209-DATA	30s	30s	0	—	—	—	—	—
50TM001210-DATA	30s	30s	0	—	—	—	—	—
50TM001208-DATA	30s	30s	0	—	—	—	—	—
50TM001212-DATA	30s	30s	0	—	—	—	—	—
50HE001312-DATA	30s	30s	0	—	—	—	—	—
50HE001316-DATA	30s	30s	0	—	—	—	—	—
50HE001313-DATA	30s	30s	0	—	—	—	—	—
50HE001317-DATA	30s	30s	0	—	—	—	—	—
50HE001314-DATA	30s	30s	0	—	—	—	—	—
50HE001318-DATA	30s	30s	0	—	—	—	—	—
50HE001315-DATA	30s	30s	0	—	—	—	—	—
50HE001319-DATA	30s	30s	0	—	—	—	—	—
50HE001320-DATA	30s	30s	0	—	—	—	—	—
50HE001321-DATA	30s	30s	0	—	—	—	—	—
50HE402586-DATA	30s	30s	0	—	—	—	—	—
50HE402591-DATA	30s	30s	0	—	—	—	—	—

**Table 19 — Basic VFD Parameters, 48/50 Units (cont)**

LOOKUP VARIABLE	VFD PARAMETER DESCRIPTION/ID					
	EFB STATION ID	EFB BAUD RATE	EFB PARITY	EFB CTRL PROFILE	COMM PROT SEL	RUN ENABLE
	5302	5303	5304	5305	9802	1601
48TM003773-DATA	—	—	—	—	—	—
48TM003776-DATA	—	—	—	—	—	—
48TM003772-DATA	—	—	—	—	—	—
48TM003784-DATA	—	—	—	—	—	—
48TM003782-DATA	—	—	—	—	—	—
48TM003777-DATA	—	—	—	—	—	—
48TM003774-DATA	—	—	—	—	—	—
48TM003783-DATA	—	—	—	—	—	—
48TM003775-DATA	—	—	—	—	—	—
48TM003778-DATA	—	—	—	—	—	—
50TM001206-DATA	—	—	—	—	—	—
50TM001211-DATA	—	—	—	—	—	—
50TM001209-DATA	—	—	—	—	—	—
50TM001210-DATA	—	—	—	—	—	—
50TM001208-DATA	—	—	—	—	—	—
50TM001212-DATA	—	—	—	—	—	—
50HE001312-DATA	—	—	—	—	—	—
50HE001316-DATA	—	—	—	—	—	—
50HE001313-DATA	—	—	—	—	—	—
50HE001317-DATA	—	—	—	—	—	—
50HE001314-DATA	—	—	—	—	—	—
50HE001318-DATA	—	—	—	—	—	—
50HE001315-DATA	—	—	—	—	—	—
50HE001319-DATA	—	—	—	—	—	—
50HE001320-DATA	—	—	—	—	—	—
50HE001321-DATA	—	—	—	—	—	—
50HE402586-DATA	—	—	—	—	—	—
50HE402591-DATA	—	—	—	—	—	—

— — Factory default setting. See label.

**Table 19 — Basic VFD Parameters, 48/50 Units (cont)**

LOOKUP VARIABLE	VFD PARAMETER DESCRIPTION/ID			CROSS REFERENCE	
	TRIAL TIME	DELAY TIME	AR OVERCURRENT	EM PKG	CL PKG
	3102	3103	3104		
48TM003773-DATA	300.0S	6.0S	(1) Enable	48TM482532	48TM482683
48TM003776-DATA	300.0S	6.0S	(1) Enable	48TM482535	48TM482686
48TM003772-DATA	300.0S	6.0S	(1) Enable	48TM482531	48TM482682
48TM003784-DATA	300.0S	6.0S	(1) Enable	48TM482593	48TM482694
48TM003782-DATA	300.0S	6.0S	(1) Enable	48TM482591	48TM482692
48TM003777-DATA	300.0S	6.0S	(1) Enable	48TM482536	48TM482687
48TM003774-DATA	300.0S	6.0S	(1) Enable	48TM482533	48TM482684
48TM003783-DATA	300.0S	6.0S	(1) Enable	48TM482592	48TM482693
48TM003775-DATA	300.0S	6.0S	(1) Enable	48TM482534	48TM482685
48TM003778-DATA	300.0S	6.0S	(1) Enable	48TM482537	48TM482688
50TM001206-DATA	300.0S	6.0S	(1) Enable	50TM480822	50TM480915
50TM001211-DATA	300.0S	6.0S	(1) Enable	50TM480842	50TM480916
50TM001209-DATA	300.0S	6.0S	(1) Enable	50TM480837	50TM480917
50TM001210-DATA	300.0S	6.0S	(1) Enable	50TM480838	50TM480918
50TM001208-DATA	300.0S	6.0S	(1) Enable	50TM480824	50TM480921
50TM001212-DATA	300.0S	6.0S	(1) Enable	50TM480843	50TM480922
50HE001312-DATA	300.0S	6.0S	(1) Enable	50HE402582	50HE402817
50HE001316-DATA	300.0S	6.0S	(1) Enable	50HE402587	50HE402822
50HE001313-DATA	300.0S	6.0S	(1) Enable	50HE402583	50HE402818
50HE001317-DATA	300.0S	6.0S	(1) Enable	50HE402588	50HE402823
50HE001314-DATA	300.0S	6.0S	(1) Enable	50HE402584	50HE402819
50HE001318-DATA	300.0S	6.0S	(1) Enable	50HE402589	50HE402824
50HE001315-DATA	300.0S	6.0S	(1) Enable	50HE402585	50HE402820
50HE001319-DATA	300.0S	6.0S	(1) Enable	50HE402590	50HE402825
50HE001320-DATA	300.0S	6.0S	(1) Enable	50HE402584	50HE402819
50HE001321-DATA	300.0S	6.0S	(1) Enable	50HE402589	50HE402824
50HE402586-DATA	300.0S	6.0S	(1) Enable	50HE402586	50HE402821
50HE402591-DATA	300.0S	6.0S	(1) Enable	50HE402591	50HE402826

**Table 20 — Basic VFD Parameters, 40RU Units (208/230 and 460V)**

LOOKUP VARIABLE	REFERENCE NUMBER ACH320	MOTOR PART NUMBER	VFD PART NUMBER	REPLACEMENT COMPONENT PART NUMBER	DRIVE HP	DESC	CONTROLS
40RU000130-DATA	40RU000130	HD56FR233	HK30WA523	HK30WA506	3	40RU 1.7 HP 230V	EM
40RU000131-DATA	40RU000131	HD56FR463	HK30WA530	HK30WA512	3	40RU 1.7 HP 460V	EM
40RU480011-DATA	40RU480011	HD56FE653	HK30WA523	HK30WA506	3	40RU 2.4 HP 230V	EM
40RU480012-DATA	40RU480012	HD56FE653	HK30WA530	HK30WA512	3	40RU 2.4 HP 460V	EM
40RU480014-DATA	40RU480014	HD58FE654	HK30WA523	HK30WA506	3	40RU 2.9 HP 230V	EM
40RU480015-DATA	40RU480015	HD58FE654	HK30WA530	HK30WA512	3	40RU 2.9 HP 460V	EM
40RU480016-DATA	40RU480016	HD60FE656	HK30WA523	HK30WA506	5	40RU 3.7 HP 230V	EM
40RU480017-DATA	40RU480017	HD60FE656	HK30WA534	HK30WA517	5	40RU 3.7 HP 460V	EM
40RU000133-DATA	40RU000133	HD58FR236	HK30WA523	HK30WA506	5	40RU 3.7 HP 230V	EM
40RU000134-DATA	40RU000134	HD58FR236	HK30WA534	HK30WA517	5	40RU 3.7 HP 460V	EM
40RU480002-DATA	40RU480002	HD60FK657	HK30WA524	HK30WA507	7.5	40RU 5.0 HP 230V	EM
40RU480003-DATA	40RU480003	HD60FK657	HK30WA532	HK30WA514	7.5	40RU 5.0 HP 460V	EM
40RU480005-DATA	40RU480005	HD62FK654	HK30WA524	HK30WA507	7.5	40RU 7.5 HP 230V	EM
40RU480006-DATA	40RU480006	HD62FK654	HK30WA532	HK30WA514	7.5	40RU 7.5 HP 460V	EM
40RU480008-DATA	40RU480008	HD64FK654	HK30WA525	HK30WA508	10	40RU 10 HP 230V	EM
40RU480009-DATA	40RU480009	HD64FK654	HK30WA533	HK30WA515	10	40RU 10 HP 460V	EM
40RU000203-DATA	40RU000203	HD56FR233	HK30WA523	HK30WA506	3	40RU 1.7 HP 230V	I/O FLEX
40RU000204-DATA	40RU000204	HD56FR463	HK30WA530	HK30WA512	3	40RU 1.7 HP 460V	I/O FLEX
40RU000218-DATA	40RU000218	HD56FE653	HK30WA523	HK30WA506	3	40RU 2.4 HP 230V	I/O FLEX
40RU000219-DATA	40RU000219	HD56FE653	HK30WA530	HK30WA512	3	40RU 2.4 HP 460V	I/O FLEX
40RU000223-DATA	40RU000223	HD60FE656	HK30WA523	HK30WA506	5	40RU 3.7 HP 230V	I/O FLEX
40RU000224-DATA	40RU000224	HD60FE656	HK30WA534	HK30WA517	5	40RU 3.7 HP 460V	I/O FLEX
40RU000206-DATA	40RU000206	HD58FR236	HK30WA523	HK30WA506	5	40RU 3.7 HP 230V	I/O FLEX
40RU000207-DATA	40RU000207	HD58FR236	HK30WA534	HK30WA517	5	40RU 3.7 HP 460V	I/O FLEX

**Table 20 — Basic VFD Parameters, 40RU Units (208/230 and 460V) (cont)**

LOOKUP VARIABLE	VFD PARAMETER DESCRIPTION/ID							
	VOLTAGE	N. AMPS	MOTOR NOM. FREQ.	N. RPM	N. HP	EXT1 COMMANDS	EXT1/EXT2 COMMANDS	REF1 SELECT
	9905	9906	9907	9908	9909	1001	1102	1103
40RU000130-DATA	230	5.8	60Hz	1725	1.7	—	—	—
40RU000131-DATA	460	2.9	60Hz	1725	1.7	—	—	—
40RU480011-DATA	230	7.1	60Hz	1725	2.4	—	—	—
40RU480012-DATA	460	3.4	60Hz	1725	2.4	—	—	—
40RU480014-DATA	230	8.6	60Hz	1725	2.9	—	—	—
40RU480015-DATA	460	3.8	60Hz	1725	2.9	—	—	—
40RU480016-DATA	230	10.8	60Hz	1725	3.7	—	—	—
40RU480017-DATA	460	4.9	60Hz	1725	3.7	—	—	—
40RU000133-DATA	230	10.2	60Hz	1725	3.7	—	—	—
40RU000134-DATA	460	4.8	60Hz	1725	3.7	—	—	—
40RU480002-DATA	230	17.0	60Hz	1760	5	—	—	—
40RU480003-DATA	460	7.6	60Hz	1760	5	—	—	—
40RU480005-DATA	230	21.5	60Hz	1760	7.5	—	—	—
40RU480006-DATA	460	14.3	60Hz	1760	7.5	—	—	—
40RU480008-DATA	230	28	60Hz	1755	10	—	—	—
40RU480009-DATA	460	15.2	60Hz	1755	10	—	—	—
40RU000203-DATA	230	5.8	60Hz	1725	1.7	(1) DI1	EXT1	AI-1
40RU000204-DATA	460	2.9	60Hz	1725	1.7	(1) DI1	EXT1	AI-1
40RU000218-DATA	230	7.1	60Hz	1725	2.4	(1) DI1	EXT1	AI-1
40RU000219-DATA	460	3.4	60Hz	1725	2.4	(1) DI1	EXT1	AI-1
40RU000223-DATA	230	10.8	60Hz	1725	3.7	(1) DI1	EXT1	AI-1
40RU000224-DATA	460	4.9	60Hz	1725	3.7	(1) DI1	EXT1	AI-1
40RU000206-DATA	230	10.2	60Hz	1725	3.7	(1) DI1	EXT1	AI-1
40RU000207-DATA	460	4.8	60Hz	1725	3.7	(1) DI1	EXT1	AI-1

**Table 20 — Basic VFD Parameters, 40RU Units (208/230 and 460V) (cont)**

LOOKUP VARIABLE	VFD PARAMETER DESCRIPTION/ID						
	CONST SPEED SELECT	CONST SPEED 1	CONST SPEED 2	CONST SPEED 3	CONST SPEED 4	RELAY OUT 1	A01 CONTENT SET
	1201	1202	1203	1204	1205	1401	1501
40RU000130-DATA	DI 2,3	40Hz	60Hz	60Hz	—	16 FLT/Alarm	—
40RU000131-DATA	DI 2,3	40Hz	60Hz	60Hz	—	16 FLT/Alarm	—
40RU480011-DATA	DI 2,3	40Hz	60Hz	60Hz	—	16 FLT/Alarm	—
40RU480012-DATA	DI 2,3	40Hz	60Hz	60Hz	—	16 FLT/Alarm	—
40RU480014-DATA	DI 2,3	40Hz	60Hz	60Hz	—	16 FLT/Alarm	—
40RU480015-DATA	DI 2,3	40Hz	60Hz	60Hz	—	16 FLT/Alarm	—
40RU480016-DATA	DI 2,3	40Hz	60Hz	60Hz	—	16 FLT/Alarm	—
40RU480017-DATA	DI 2,3	40Hz	60Hz	60Hz	—	16 FLT/Alarm	—
40RU000133-DATA	DI 2,3	40Hz	60Hz	60Hz	—	16 FLT/Alarm	—
40RU000134-DATA	DI 2,3	40Hz	60Hz	60Hz	—	16 FLT/Alarm	—
40RU480002-DATA	DI 2,3	40Hz	60Hz	60Hz	—	16 FLT/Alarm	—
40RU480003-DATA	DI 2,3	40Hz	60Hz	60Hz	—	16 FLT/Alarm	—
40RU480005-DATA	DI 2,3	40Hz	60Hz	60Hz	—	16 FLT/Alarm	—
40RU480006-DATA	DI 2,3	40Hz	60Hz	60Hz	—	16 FLT/Alarm	—
40RU480008-DATA	DI 2,3	40Hz	60Hz	60Hz	—	16 FLT/Alarm	—
40RU480009-DATA	DI 2,3	40Hz	60Hz	60Hz	—	16 FLT/Alarm	—
40RU000203-DATA	DI 2,3	40Hz	60Hz	60Hz	—	16 FLT/Alarm	0103 OUTPUT FREQ
40RU000204-DATA	DI 2,3	40Hz	60Hz	60Hz	—	16 FLT/Alarm	0103 OUTPUT FREQ
40RU000218-DATA	DI 2,3	40Hz	60Hz	60Hz	—	16 FLT/Alarm	0103 OUTPUT FREQ
40RU000219-DATA	DI 2,3	40Hz	60Hz	60Hz	—	16 FLT/Alarm	0103 OUTPUT FREQ
40RU000223-DATA	DI 2,3	40Hz	60Hz	60Hz	—	16 FLT/Alarm	0103 OUTPUT FREQ
40RU000224-DATA	DI 2,3	40Hz	60Hz	60Hz	—	16 FLT/Alarm	0103 OUTPUT FREQ
40RU000206-DATA	DI 2,3	40Hz	60Hz	60Hz	—	16 FLT/Alarm	0103 OUTPUT FREQ
40RU000207-DATA	DI 2,3	40Hz	60Hz	60Hz	—	16 FLT/Alarm	0103 OUTPUT FREQ

— — Factory default setting. See label.

**Table 20 — Basic VFD Parameters, 40RU Units (208/230 and 460V) (cont)**

LOOKUP VARIABLE	VFD PARAMETER DESCRIPTION/ID							
	PARAMETER VIEW	MAX AMPS	MIN FREQ	MAX FREQ	SWITCH FREQ	START FCN	STOP FCN	ACCEL/ DECEL
	1611	2003	2007	2008	2606	2101	2102	2201
40RU000130-DATA	3	6.7	0Hz	60Hz	4kHz	Auto	(1) Coast	Not Sel
40RU000131-DATA	3	3.3	0Hz	60Hz	4kHz	Auto	(1) Coast	Not Sel
40RU480011-DATA	3	8.2	0Hz	60Hz	4kHz	Auto	(1) Coast	Not Sel
40RU480012-DATA	3	3.9	0Hz	60Hz	4kHz	Auto	(1) Coast	Not Sel
40RU480014-DATA	3	9.9	0Hz	60Hz	4kHz	Auto	(1) Coast	Not Sel
40RU480015-DATA	3	4.4	0Hz	60Hz	4kHz	Auto	(1) Coast	Not Sel
40RU480016-DATA	3	12.4	0Hz	60Hz	4kHz	Auto	(1) Coast	Not Sel
40RU480017-DATA	3	5.6	0Hz	60Hz	4kHz	Auto	(1) Coast	Not Sel
40RU000133-DATA	3	11.7	0Hz	60Hz	4kHz	Auto	(1) Coast	Not Sel
40RU000134-DATA	3	5.5	0Hz	60Hz	4kHz	Auto	(1) Coast	Not Sel
40RU480002-DATA	3	19.6	0Hz	60Hz	4kHz	Auto	(1) Coast	Not Sel
40RU480003-DATA	3	8.7	0Hz	60Hz	4kHz	Auto	(1) Coast	Not Sel
40RU480005-DATA	3	24.7	0Hz	60Hz	4kHz	Auto	(1) Coast	Not Sel
40RU480006-DATA	3	16.4	0Hz	60Hz	4kHz	Auto	(1) Coast	Not Sel
40RU480008-DATA	3	32.2	0Hz	60Hz	4kHz	Auto	(1) Coast	Not Sel
40RU480009-DATA	3	17.5	0Hz	60Hz	4kHz	Auto	(1) Coast	Not Sel
40RU000203-DATA	3	6.7	0Hz	60Hz	4kHz	(1) AUTO	(1) Coast	(0) NOT SEL
40RU000204-DATA	3	3.3	0Hz	60Hz	4kHz	(1) AUTO	(1) Coast	(0) NOT SEL
40RU000218-DATA	3	8.2	0Hz	60Hz	4kHz	(1) AUTO	(1) Coast	(0) NOT SEL
40RU000219-DATA	3	3.9	0Hz	60Hz	4kHz	(1) AUTO	(1) Coast	(0) NOT SEL
40RU000223-DATA	3	12.4	0Hz	60Hz	4kHz	(1) AUTO	(1) Coast	(0) NOT SEL
40RU000224-DATA	3	5.6	0Hz	60Hz	4kHz	(1) AUTO	(1) Coast	(0) NOT SEL
40RU000206-DATA	3	11.7	0Hz	60Hz	4kHz	(1) AUTO	(1) Coast	(0) NOT SEL
40RU000207-DATA	3	5.5	0Hz	60Hz	4kHz	(1) AUTO	(1) Coast	(0) NOT SEL

**Table 20 — Basic VFD Parameters, 40RU Units (208/230 and 460V) (cont)**

LOOKUP VARIABLE	VFD PARAMETER DESCRIPTION/ID							
	ACCEL	DECEL	IR COMP VOLT	FBA TYPE	STATION ID	BAUD RATE	PARITY	EFB PROTOCOL ID
	2202	2203	2603	5101	5201	5202	5203	5301
40RU000130-DATA	30s	30s	0	—	—	—	—	—
40RU000131-DATA	30s	30s	0	—	—	—	—	—
40RU480011-DATA	30s	30s	0	—	—	—	—	—
40RU480012-DATA	30s	30s	0	—	—	—	—	—
40RU480014-DATA	30s	30s	0	—	—	—	—	—
40RU480015-DATA	30s	30s	0	—	—	—	—	—
40RU480016-DATA	30s	30s	0	—	—	—	—	—
40RU480017-DATA	30s	30s	0	—	—	—	—	—
40RU000133-DATA	30s	30s	0	—	—	—	—	—
40RU000134-DATA	30s	30s	0	—	—	—	—	—
40RU480002-DATA	30s	30s	0	—	—	—	—	—
40RU480003-DATA	30s	30s	0	—	—	—	—	—
40RU480005-DATA	30s	30s	0	—	—	—	—	—
40RU480006-DATA	30s	30s	0	—	—	—	—	—
40RU480008-DATA	30s	30s	0	—	—	—	—	—
40RU480009-DATA	30s	30s	0	—	—	—	—	—
40RU000203-DATA	30s	10.0s	0	—	—	—	—	—
40RU000204-DATA	30s	10.0s	0	—	—	—	—	—
40RU000218-DATA	30s	10.0s	0	—	—	—	—	—
40RU000219-DATA	30s	10.0s	0	—	—	—	—	—
40RU000223-DATA	30s	10.0s	0	—	—	—	—	—
40RU000224-DATA	30s	10.0s	0	—	—	—	—	—
40RU000206-DATA	30s	10.0s	0	—	—	—	—	—
40RU000207-DATA	30s	10.0s	0	—	—	—	—	—

— — Factory default setting. See label.

**Table 20 — Basic VFD Parameters, 40RU Units (208/230 and 460V) (cont)**

LOOKUP VARIABLE	VFD PARAMETER DESCRIPTION/ID					
	EFB STATION ID	EFB BAUD RATE	EFB PARITY	EFB CTRL PROFILE	COMM PROT SEL	RUN ENABLE
	5302	5303	5304	5305	9802	1601
40RU000130-DATA	—	—	—	—	—	—
40RU000131-DATA	—	—	—	—	—	—
40RU480011-DATA	—	—	—	—	—	—
40RU480012-DATA	—	—	—	—	—	—
40RU480014-DATA	—	—	—	—	—	—
40RU480015-DATA	—	—	—	—	—	—
40RU480016-DATA	—	—	—	—	—	—
40RU480017-DATA	—	—	—	—	—	—
40RU000133-DATA	—	—	—	—	—	—
40RU000134-DATA	—	—	—	—	—	—
40RU480002-DATA	—	—	—	—	—	—
40RU480003-DATA	—	—	—	—	—	—
40RU480005-DATA	—	—	—	—	—	—
40RU480006-DATA	—	—	—	—	—	—
40RU480008-DATA	—	—	—	—	—	—
40RU480009-DATA	—	—	—	—	—	—
40RU000203-DATA	1	76.8kb/s	8 NONE 1	—	BACnet	DI-1
40RU000204-DATA	1	76.8kb/s	8 NONE 1	—	BACnet	DI-2
40RU000218-DATA	1	76.8kb/s	8 NONE 1	—	BACnet	DI-3
40RU000219-DATA	1	76.8kb/s	8 NONE 1	—	BACnet	DI-4
40RU000223-DATA	1	76.8kb/s	8 NONE 1	—	BACnet	DI-5
40RU000224-DATA	1	76.8kb/s	8 NONE 1	—	BACnet	DI-6
40RU000206-DATA	1	76.8kb/s	8 NONE 1	—	BACnet	DI-7
40RU000207-DATA	1	76.8kb/s	8 NONE 1	—	BACnet	DI-8

**Table 20 — Basic VFD Parameters, 40RU Units (208/230 and 460V) (cont)**

LOOKUP VARIABLE	VFD PARAMETER DESCRIPTION/ID			CROSS REFERENCE	
	TRIAL TIME	DELAY TIME	AR OVERCURRENT	EM PKG	CL PKG
	3102	3103	3104		
40RU000130-DATA	300.0S	6.0S	(1) Enable	40RU480130	—
40RU000131-DATA	300.0S	6.0S	(1) Enable	40RU480131	—
40RU480011-DATA	300.0S	6.0S	(1) Enable	40RU480011	—
40RU480012-DATA	300.0S	6.0S	(1) Enable	40RU480012	—
40RU480014-DATA	300.0S	6.0S	(1) Enable	40RU480014	—
40RU480015-DATA	300.0S	6.0S	(1) Enable	40RU480015	—
40RU480016-DATA	300.0S	6.0S	(1) Enable	40RU480016	—
40RU480017-DATA	300.0S	6.0S	(1) Enable	40RU480017	—
40RU000133-DATA	300.0S	6.0S	(1) Enable	40RU480133	—
40RU000134-DATA	300.0S	6.0S	(1) Enable	40RU480134	—
40RU480002-DATA	300.0S	6.0S	(1) Enable	40RU480002	—
40RU480003-DATA	300.0S	6.0S	(1) Enable	40RU480003	—
40RU480005-DATA	300.0S	6.0S	(1) Enable	40RU480005	—
40RU480006-DATA	300.0S	6.0S	(1) Enable	40RU480006	—
40RU480008-DATA	300.0S	6.0S	(1) Enable	40RU480008	—
40RU480009-DATA	300.0S	6.0S	(1) Enable	40RU480009	—
40RU000203-DATA	300.0S	6.0S	(1) Enable	40RU480130	—
40RU000204-DATA	300.0S	6.0S	(1) Enable	40RU480131	—
40RU000218-DATA	300.0S	6.0S	(1) Enable	40RU480011	—
40RU000219-DATA	300.0S	6.0S	(1) Enable	40RU480012	—
40RU000223-DATA	300.0S	6.0S	(1) Enable	40RU480016	—
40RU000224-DATA	300.0S	6.0S	(1) Enable	40RU480017	—
40RU000206-DATA	300.0S	6.0S	(1) Enable	40RU480133	—
40RU000207-DATA	300.0S	6.0S	(1) Enable	40RU480134	—

— — Factory default setting. See label.

**Table 21 — Basic VFD Parameters, 40RU Units (575V)**

LOOKUP VARIABLE	REFERENCE NUMBER ACH550	MOTOR PART NUMBER	VFD PART NUMBER	REPLACEMENT COMPONENT PART NUMBER	DRIVE HP	DESC	CONTROLS
40RU000132-DATA	40RU000132	HD56FR579	HK30WA360	HK30WA333	3	40RU 1.7 HP 575V	EM
40RU480013-DATA	40RU480013	HD56FE577	HK30WA360	HK30WA333	3	40RU 2.4 HP 575V	EM
40RU480018-DATA	40RU480018	HD58FE577	HK30WA361	HK30WA334	5	40RU 3.7 HP 575V	EM
40RU000135-DATA	40RU000135	HD58FE577	HK30WA361	HK30WA334	5	40RU 3.7 HP 575V	EM
40RU480004-DATA	40RU480004	HD60FK577	HK30WA362	HK30WA335	7.5	40RU 5.0 HP 575V	EM
40RU480007-DATA	40RU480007	HD62FL576	HK30WA362	HK30WA335	7.5	40RU 7.5 HP 575V	EM
40RU480010-DATA	40RU480010	HD64FL576	HK30WA363	HK30WA336	10	40RU 10 HP 575V	EM
40RU000205-DATA	40RU000205	HD56FR579	HK30WA360	HK30WA333	3	40RU 1.7 HP 575V	I/O FLEX
40RU000220-DATA	40RU000220	HD56FE577	HK30WA360	HK30WA333	3	40RU 2.4 HP 575V	I/O FLEX
40RU000225-DATA	40RU000225	HD58FE577	HK30WA361	HK30WA334	5	40RU 3.7 HP 575V	I/O FLEX
40RU000208-DATA	40RU000208	HD58FE577	HK30WA361	HK30WA334	5	40RU 3.7 HP 575V	I/O FLEX

**Table 21 — Basic VFD Parameters, 40RU Units (575V) (cont)**

LOOKUP VARIABLE	VFD PARAMETER DESCRIPTION/ID								
	APPLIC MACRO	VOLTAGE	N. AMPS	MOTOR NOM. FREQ.	N. RPM	N. HP	EXT1 COMMANDS	EXT1/EXT2 COMMANDS	REF1 SELECT
	9902	9905	9906	9907	9908	9909	1001	1102	1103
40RU000132-DATA	HVAC DEFAULT	575	2.8	60Hz	1725	1.7	—	—	—
40RU480013-DATA	HVAC DEFAULT	575	3.8	60Hz	1725	2.4	—	—	—
40RU480018-DATA	HVAC DEFAULT	575	4.9	60Hz	1725	3.7	—	—	—
40RU000135-DATA	HVAC DEFAULT	575	4.5	60Hz	1725	3.7	—	—	—
40RU480004-DATA	HVAC DEFAULT	575	8.0	60Hz	1725	5	—	—	—
40RU480007-DATA	HVAC DEFAULT	575	9.0	60Hz	1725	7.5	—	—	—
40RU480010-DATA	HVAC DEFAULT	575	11.0	60Hz	1725	10	—	—	—
40RU000205-DATA	HVAC DEFAULT	575	2.8	60Hz	1725	1.7	10 COMM	8 COMM	8 COMM
40RU000220-DATA	HVAC DEFAULT	575	3.8	60Hz	1725	2.4	10 COMM	8 COMM	8 COMM
40RU000225-DATA	HVAC DEFAULT	575	4.9	60Hz	1725	3.7	10 COMM	8 COMM	8 COMM
40RU000208-DATA	HVAC DEFAULT	575	4.5	60Hz	1725	3.7	10 COMM	8 COMM	8 COMM

**Table 21 — Basic VFD Parameters, 40RU Units (575V) (cont)**

LOOKUP VARIABLE	VFD PARAMETER DESCRIPTION/ID							
	CONST SPEED SELECT	CONST SPEED 1	CONST SPEED 2	CONST SPEED 3	CONST SPEED 4	RELAY OUT 1	RELAY OUT 3	A01 CONTENT SET
	1201	1202	1203	1204	1205	1401	1403	1501
40RU000132-DATA	DI 2,3	40Hz	60Hz	60Hz	—	—	16 FLT/Alarm	—
40RU480013-DATA	DI 2,3	40Hz	60Hz	60Hz	—	—	16 FLT/Alarm	—
40RU480018-DATA	DI 2,3	40Hz	60Hz	60Hz	—	—	16 FLT/Alarm	—
40RU000135-DATA	DI 2,3	40Hz	60Hz	60Hz	—	—	16 FLT/Alarm	—
40RU480004-DATA	DI 2,3	40Hz	60Hz	60Hz	—	—	16 FLT/Alarm	—
40RU480007-DATA	DI 2,3	40Hz	60Hz	60Hz	—	—	16 FLT/Alarm	—
40RU480010-DATA	DI 2,3	40Hz	60Hz	60Hz	—	—	16 FLT/Alarm	—
40RU000205-DATA	DI 3	40Hz	60Hz	60Hz	—	—	4 Fault	102 Speed
40RU000220-DATA	DI 3	40Hz	60Hz	60Hz	—	—	4 Fault	102 Speed
40RU000225-DATA	DI 3	40Hz	60Hz	60Hz	—	—	4 Fault	102 Speed
40RU000208-DATA	DI 3	40Hz	60Hz	60Hz	—	—	4 Fault	102 Speed

— — Factory default setting. See label.



**Table 21 — Basic VFD Parameters, 40RU Units (575V) (cont)**

LOOKUP VARIABLE	VFD PARAMETER DESCRIPTION/ID								
	MAX AMPS	MIN FREQ	MAX FREQ	SWITCH FREQ	START FCN	STOP FCN	ACCEL/ DECEL	ACCEL	DECEL
	2003	2007	2008	2606	2101	2102	2201	2202	2203
40RU000132-DATA	3.2	0Hz	60Hz	4kHz	Auto	Ramp	Not Sel	30s	30s
40RU480013-DATA	4.4	0Hz	60Hz	4kHz	Auto	Ramp	Not Sel	30s	30s
40RU480018-DATA	5.6	0Hz	60Hz	4kHz	Auto	Ramp	Not Sel	30s	30s
40RU000135-DATA	5.2	0Hz	60Hz	4kHz	Auto	Ramp	Not Sel	30s	30s
40RU480004-DATA	9.2	0Hz	60Hz	4kHz	Auto	Ramp	Not Sel	30s	30s
40RU480007-DATA	10.4	0Hz	60Hz	4kHz	Auto	Ramp	Not Sel	30s	30s
40RU480010-DATA	12.7	0Hz	60Hz	4kHz	Auto	Ramp	Not Sel	30s	30s
40RU000205-DATA	3.2	0Hz	60Hz	4kHz	Auto	Ramp	Not Sel	30s	30s
40RU000220-DATA	4.4	0Hz	60Hz	4kHz	Auto	Ramp	Not Sel	30s	30s
40RU000225-DATA	5.6	0Hz	60Hz	4kHz	Auto	Ramp	Not Sel	30s	30s
40RU000208-DATA	5.2	0Hz	60Hz	4kHz	Auto	Ramp	Not Sel	30s	30s

**Table 21 — Basic VFD Parameters, 40RU Units (575V) (cont)**

LOOKUP VARIABLE	VFD PARAMETER DESCRIPTION/ID								
	FBA TYPE	STATION ID	BAUD RATE	PARITY	EFB PROTOCOL ID	EFB STATION ID	EFB BAUD RATE	EFB PARITY	EFB CTRL PROFILE
	5101	5201	5202	5203	5301	5302	5303	5304	5305
40RU000132-DATA	—	—	—	—	—	—	—	—	—
40RU480013-DATA	—	—	—	—	—	—	—	—	—
40RU480018-DATA	—	—	—	—	—	—	—	—	—
40RU000135-DATA	—	—	—	—	—	—	—	—	—
40RU480004-DATA	—	—	—	—	—	—	—	—	—
40RU480007-DATA	—	—	—	—	—	—	—	—	—
40RU480010-DATA	—	—	—	—	—	—	—	—	—
40RU000205-DATA	64 ModBus Plus	1	9.6 kb/s	8 NONE 1	—	—	—	—	—
40RU000220-DATA	64 ModBus Plus	1	9.6 kb/s	8 NONE 1	—	—	—	—	—
40RU000225-DATA	64 ModBus Plus	1	9.6 kb/s	8 NONE 1	—	—	—	—	—
40RU000208-DATA	64 ModBus Plus	1	9.6 kb/s	8 NONE 1	—	—	—	—	—

**Table 21 — Basic VFD Parameters, 40RU Units (575V) (cont)**

LOOKUP VARIABLE	VFD PARAMETER DESCRIPTION/ID		CROSS REFERENCE	
	COMM PROT SEL	RUN ENABLE	EM PKG	CL PKG
	9802	1601		
40RU000132-DATA	—	—	40RU480132	—
40RU480013-DATA	—	—	40RU480013	—
40RU480018-DATA	—	—	40RU480018	—
40RU000135-DATA	—	—	40RU480135	—
40RU480004-DATA	—	—	40RU480004	—
40RU480007-DATA	—	—	40RU480007	—
40RU480010-DATA	—	—	40RU480010	—
40RU000205-DATA	1 Std Modbus	—	40RU480132	—
40RU000220-DATA	1 Std Modbus	—	40RU480013	—
40RU000225-DATA	1 Std Modbus	—	40RU480018	—
40RU000208-DATA	1 Std Modbus	—	40RU480135	—

— — Factory default setting. See label.

## APPENDIX A — REMOTE VFD KEYPAD REFERENCE

NOTE: This Appendix only applies when a unit with the factory-installed SAV™ option is equipped with the field-installed Remote VFD Keypad (Part Number: CRDISKKIT001A00).

On 48/50 Series single package rooftop units and 40RU fan coils equipped with the SAV option, the supply fan speed is controlled by a 3-phase VFD. See Fig. 5-22 for the location of the VFD in the units covered by this supplement.

The VFD is powered during normal operation to prevent condensation from forming on the boards during the off mode and is stopped by driving the speed to 0. The units use ABB VFDs. The interface wiring for the VFDs is shown in Fig. 28 and 29 (on page 21). Terminal designations are shown in the Terminal Designation table (see Tables 12 and 13 on page 21). Configurations are shown in the VFD Parameters tables (see Tables A-G on pages 43-49).

### VFD Operation with Remote Keypad

The VFD keypad is shown in Fig. A. The functions of SOFT KEYS 1 and 2 change depending on what is displayed on the screen. The function of SOFT KEY 1 matches the word in the lower left-hand box on the display screen. The function of SOFT KEY 2 matches the word in the lower right-hand box on the display screen. If the box is empty, then the SOFT KEY does not have a function on that specific screen. The UP and DOWN keys are used to navigate through the menus. The OFF key is used to turn off the VFD. The AUTO key is used to change control of the drive to automatic control. The HAND key is used to change control of the drive to local (hand held) control. The HELP button is used to access the help screens.

For the VFD to operate on the units covered by this document, the drive must be set in AUTO mode. The word “AUTO” will appear in the upper left hand corner of the VFD display. Press the AUTO button to set the drive in AUTO mode.

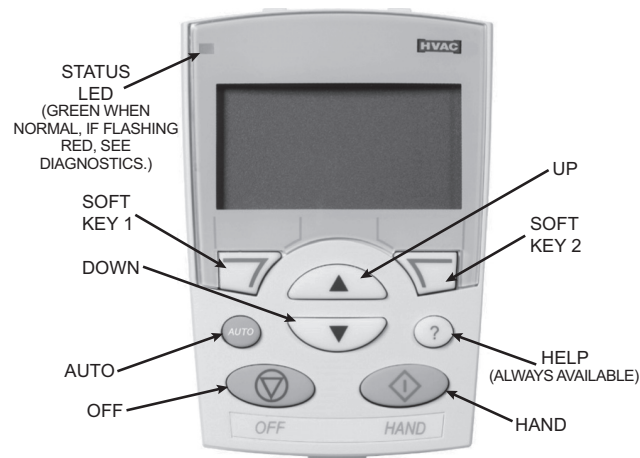


Fig. A — VFD Keypad

### START UP WITH ASSISTANT

Initial start-up has been performed at the factory. Use of the start up assistant will override factory VFD configurations.

**⚠ CAUTION**

**CONFIGURATION OVERRIDE HAZARD**

DO NOT USE ABB OR CARRIER START-UP ASSISTANT ON THIS VFD APPLICATION! Use of start-up assistant will override the factory VFD configurations!

### START UP BY CHANGING PARAMETERS INDIVIDUALLY

Initial start-up is performed at the factory. To start up the VFD by changing individual parameters, perform the following procedure:

1. Select MENU (SOFT KEY 2). The Main menu will be displayed.
2. Use the UP or DOWN keys to highlight PARAMETERS on the display screen and press ENTER (SOFT KEY 2).
3. Use the UP or DOWN keys to highlight the desired parameter group and press SEL (SOFT KEY 2).
4. Use the UP or DOWN keys to highlight the desired parameter and press EDIT (SOFT KEY 2).
5. Use the UP or DOWN keys to change the value of the parameter.
6. Press SAVE (SOFT KEY 2) to store the modified value. Press CANCEL (SOFT KEY 1) to keep the previous value. Any modifications that are not saved will not be changed.
7. Choose another parameter or press EXIT (SOFT KEY 1) to return to the listing of parameter groups. Continue until all the parameters have been configured and then press EXIT (SOFT KEY 1) to return to the main menu.

NOTE: The current parameter value appears above the highlight parameter. To view the default parameter value, press the UP and DOWN keys simultaneously. To restore the default factory settings, select the application macro “HVAC Default.”

### VFD Modes

The VFD has several different modes for configuring, operating, and diagnosing the VFD. The modes are:

1. Standard Display mode — shows drive status information and operates the drive
2. Parameters mode — edits parameter values individually
3. Start-up Assistant mode — guides the start up and configuration
4. Changed Parameters mode — shows all changed parameters
5. Drive Parameter Backup mode — stores or uploads the parameters
6. Clock Set mode — sets the time and date for the drive
7. I/O Settings mode — checks and edits the I/O settings

**APPENDIX A — REMOTE VFD KEYPAD REFERENCE (CONT)**

**Table A — ACH550 VFD Parameters — 48/50TC 07-14 (575V), 50TCQ 07-12 (575V), 48/50HC 07-12 and 50HCQ 08-09**

VFD PART NUMBER	REPLACEMENT COMPONENT PART NUMBER	DESC	MOTOR PART NUMBER	VOLT (9905)	NOM AMPS (9906)	MOTOR NOM FREQ (9907)	NOM RPM (9908)	NOM HP (9909)	CONST SPEED SEL (1201)	CONT SPEED 1 (1202)	CONST SPEED 2 (1203)	CONST SPEED 3 (1204)	RELAY OUT 3 (1403)	MAX AMPS (2003)	MIN FREQ (2007)	MAX FREQ (2008)	SWITCH FREQ (2606)	START FCN (2101)	STOP FCN (2102)	ACCEL/ DECEL (2201)	ACCEL (2202)	DECEL (2203)
HK30WA364	HK30WA302	1.7 HP 230V	HD56FR233	230	5.8	60 Hz	1725	1.7	DI 2,3	40 Hz	60 Hz	60 Hz	16 FLT/ Alarm	6.7	0 Hz	60 Hz	4 kHz	Auto	Ramp	Not Sel	30 sec	30 sec
HK30WA356	HK30WA318	1.7 HP 460V	HD56FR463	460	2.9	60 Hz	1725	1.7	DI 2,3	40 Hz	60 Hz	60 Hz	16 FLT/ Alarm	3.3	0 Hz	60 Hz	4 kHz	Auto	Ramp	Not Sel	30 sec	30 sec
HK30WA366	HK30WA332	1.7 HP 575V	HD56FR579	575	3.1	60 Hz	1725	1.7	DI 2,3	40 Hz	60 Hz	60 Hz	16 FLT/ Alarm	3.6	0 Hz	60 Hz	4 kHz	Auto	Ramp	Not Sel	30 sec	30 sec
HK30WA352	HK30WA303	2.4 HP 230V	HD56FE653	230	7.9	60 Hz	1725	2.4	DI 2,3	40 Hz	60 Hz	60 Hz	16 FLT/ Alarm	9.1	0 Hz	60 Hz	4 kHz	Auto	Ramp	Not Sel	30 sec	30 sec
HK30WA356	HK30WA318	2.4 HP 460V	HD56FE653	460	4.0	60 Hz	1725	2.4	DI 2,3	40 Hz	60 Hz	60 Hz	16 FLT/ Alarm	4.6	0 Hz	60 Hz	4 kHz	Auto	Ramp	Not Sel	30 sec	30 sec
HK30WA360	HK30WA333	2.4 HP 575V	HD56FE577	575	3.4	60 Hz	1725	2.4	DI 2,3	40 Hz	60 Hz	60 Hz	16 FLT/ Alarm	3.9	0 Hz	60 Hz	4 kHz	Auto	Ramp	Not Sel	30 sec	30 sec
HK30WA352	HK30WA303	2.9 HP 230V	HD58FE654	230	9.2	60 Hz	1725	2.9	DI 2,3	40 Hz	60 Hz	60 Hz	16 FLT/ Alarm	10.6	0 Hz	60 Hz	4 kHz	Auto	Ramp	Not Sel	30 sec	30 sec
HK30WA356	HK30WA318	2.9 HP 460V	HD58FE654	460	4.6	60 Hz	1725	2.9	DI 2,3	40 Hz	60 Hz	60 Hz	16 FLT/ Alarm	5.3	0 Hz	60 Hz	4 kHz	Auto	Ramp	Not Sel	30 sec	30 sec
HK30WA353	HK30WA304	3.7 HP 230V	HD60FE656	230	11.2	60 Hz	1725	3.7	DI 2,3	40 Hz	60 Hz	60 Hz	16 FLT/ Alarm	12.9	0 Hz	60 Hz	4 kHz	Auto	Ramp	Not Sel	30 sec	30 sec
HK30WA357	HK30WA319	3.7 HP 460V	HD60FE656	460	5.6	60 Hz	1725	3.7	DI 2,3	40 Hz	60 Hz	60 Hz	16 FLT/ Alarm	6.4	0 Hz	60 Hz	4 kHz	Auto	Ramp	Not Sel	30 sec	30 sec
HK30WA361	HK30WA334	3.7 HP 575V	HD58FE577	575	4.2	60 Hz	1725	3.7	DI 2,3	40 Hz	60 Hz	60 Hz	16 FLT/ Alarm	4.8	0 Hz	60 Hz	4 kHz	Auto	Ramp	Not Sel	30 sec	30 sec
HK30WA354	HK30WA305	5.3 HP 230V	HD60FK658	230	13.6	60 Hz	1740	5.3	DI 2,3	40 Hz	60 Hz	60 Hz	16 FLT/ Alarm	15.6	0 Hz	60 Hz	4 kHz	Auto	Ramp	Not Sel	30 sec	30 sec
HK30WA358	HK30WA320	5.3 HP 460V	HD60FK658	460	6.4	60 Hz	1740	5.3	DI 2,3	40 Hz	60 Hz	60 Hz	16 FLT/ Alarm	7.4	0 Hz	60 Hz	4 kHz	Auto	Ramp	Not Sel	30 sec	30 sec
HK30WA362	HK30WA335	5.3 HP 575V	HD60FE576	575	5.4	60 Hz	1725	5.3	DI 2,3	40 Hz	60 Hz	60 Hz	16 FLT/ Alarm	6.2	0 Hz	60 Hz	4 kHz	Auto	Ramp	Not Sel	30 sec	30 sec

**APPENDIX A — REMOTE VFD KEYPAD REFERENCE (CONT)**

**Table B — ACH550 VFD Parameters — 48/50TC 16 (575V), 50TCQ 14 (575V), 48/50HC 14 and 50HCQ 12**

VFD PART NUMBER	REPLACEMENT COMPONENT PART NUMBER	DESC	MOTOR PART NUMBER	VOLT (9905)	NOM AMPS (9906)	MOTOR NOM FREQ (9907)	NOM RPM (9908)	NOM HP (9909)	CONST SPEED SEL (1201)	CONT SPEED 1 (1202)	CONST SPEED 2 (1203)	CONST SPEED 3 (1204)	RELAY OUT 3 (1403)	MAX AMPS (2003)	MIN FREQ (2007)	MAX FREQ (2008)	SWITCH FREQ (2606)	START FCN (2101)	STOP FCN (2102)	ACCEL/ DECEL (2201)	ACCEL (2202)	DECEL (2203)
HK30WA352	HK30WA303	2.4 HP 230V	HD56FE653	230	7.9	60 Hz	1725	2.4	DI 2,3	40 Hz	60 Hz	60 Hz	16 FLT/ Alarm	9.1	0 Hz	60 Hz	4 kHz	Auto	Ramp	Not Sel	30 sec	30 sec
HK30WA356	HK30WA318	2.4 HP 460V	HD56FE653	460	4.0	60 Hz	1725	2.4	DI 2,3	40 Hz	60 Hz	60 Hz	16 FLT/ Alarm	4.6	0 Hz	60 Hz	4 kHz	Auto	Ramp	Not Sel	30 sec	30 sec
HK30WA360	HK30WA333	2.4 HP 575V	HD56FE577	575	3.4	60 Hz	1725	2.4	DI 2,3	40 Hz	60 Hz	60 Hz	16 FLT/ Alarm	3.9	0 Hz	60 Hz	4 kHz	Auto	Ramp	Not Sel	30 sec	30 sec
HK30WA352	HK30WA303	2.9 HP 230V	HD58FE654	230	9.2	60 Hz	1725	2.9	DI 2,3	40 Hz	60 Hz	60 Hz	16 FLT/ Alarm	10.6	0 Hz	60 Hz	4 kHz	Auto	Ramp	Not Sel	30 sec	30 sec
HK30WA356	HK30WA318	2.9 HP 460V	HD58FE654	460	4.6	60 Hz	1725	2.9	DI 2,3	40 Hz	60 Hz	60 Hz	16 FLT/ Alarm	5.3	0 Hz	60 Hz	4 kHz	Auto	Ramp	Not Sel	30 sec	30 sec
HK30WA353	HK30WA304	3.7 HP 230V	HD60FE656	230	11.2	60 Hz	1725	3.7	DI 2,3	40 Hz	60 Hz	60 Hz	16 FLT/ Alarm	12.9	0 Hz	60 Hz	4 kHz	Auto	Ramp	Not Sel	30 sec	30 sec
HK30WA357	HK30WA319	3.7 HP 460V	HD60FE656	460	5.6	60 Hz	1725	3.7	DI 2,3	40 Hz	60 Hz	60 Hz	16 FLT/ Alarm	6.4	0 Hz	60 Hz	4 kHz	Auto	Ramp	Not Sel	30 sec	30 sec
HK30WA361	HK30WA334	3.7 HP 575V	HD58FE577	575	4.2	60 Hz	1725	3.7	DI 2,3	40 Hz	60 Hz	60 Hz	16 FLT/ Alarm	4.8	0 Hz	60 Hz	4 kHz	Auto	Ramp	Not Sel	30 sec	30 sec
HK30WA354	HK30WA305	5.0 HP 230V	HD60FL657	230	16.7	60 Hz	1745	5.0	DI 2,3	40 Hz	60 Hz	60 Hz	16 FLT/ Alarm	19.2	0 Hz	60 Hz	4 kHz	Auto	Ramp	Not Sel	30 sec	30 sec
HK30WA358	HK30WA320	5.0 HP 460V	HD60FL657	460	8.4	60 Hz	1745	5.0	DI 2,3	40 Hz	60 Hz	60 Hz	16 FLT/ Alarm	9.7	0 Hz	60 Hz	4 kHz	Auto	Ramp	Not Sel	30 sec	30 sec
HK30WA362	HK30WA335	5.0 HP 575V	HD60FL575	575	5.1	60 Hz	1725	5.0	DI 2,3	40 Hz	60 Hz	60 Hz	16 FLT/ Alarm	5.9	0 Hz	60 Hz	4 kHz	Auto	Ramp	Not Sel	30 sec	30 sec
HK30WA354	HK30WA305	5.0 HP 230V	HD60FK657	230	14.7	60 Hz	1760	5.0	DI 2,3	40 Hz	60 Hz	60 Hz	16 FLT/ Alarm	16.9	0 Hz	60 Hz	4 kHz	Auto	Ramp	Not Sel	30 sec	30 sec
HK30WA358	HK30WA320	5.0 HP 460V	HD60FK657	460	6.8	60 Hz	1760	5.0	DI 2,3	40 Hz	60 Hz	60 Hz	16 FLT/ Alarm	7.8	0 Hz	60 Hz	4 kHz	Auto	Ramp	Not Sel	30 sec	30 sec
HK30WA362	HK30WA335	5.0 HP 575V	HD60FL576	575	5.4	60 Hz	1745	5.0	DI 2,3	40 Hz	60 Hz	60 Hz	16 FLT/ Alarm	6.2	0 Hz	60 Hz	4 kHz	Auto	Ramp	Not Sel	30 sec	30 sec

**APPENDIX A — REMOTE VFD KEYPAD REFERENCE (CONT)**

**Table C — ACH550 VFD Parameters — 48/50TC17-30 (575V), 50TCQ 17-24 (575V) and 48/50HC 17-28**

VFD PART NUMBER	REPLACEMENT COMPONENT PART NUMBER	DESC	MOTOR PART NUMBER	VOLT (9905)	NOM AMPS (9906)	MOTOR NOM FREQ (9907)	NOM RPM (9908)	NOM HP (9909)	CONST SPEED SEL (1201)	CONT SPEED 1 (1202)	CONST SPEED 2 (1203)	CONST SPEED 3 (1204)	RELAY OUT 3 (1403)	MAX AMPS (2003)	MIN FREQ (2007)	MAX FREQ (2008)	SWITCH FREQ (2606)	START FCN (2101)	STOP FCN (2102)	ACCEL/ DECEL (2201)	ACCEL (2202)	DECEL (2203)
HK30WA352	HK30WA303	2.9 HP 230V	HD58FE654	230	9.2	60 Hz	1725	2.9	DI 2,3	40 Hz	60 Hz	60 Hz	16 FLT/ Alarm	10.6	0 Hz	60 Hz	4 kHz	Auto	Ramp	Not Sel	30 sec	30 sec
HK30WA356	HK30WA318	2.9 HP 460V	HD58FE654	460	4.6	60 Hz	1725	2.9	DI 2,3	40 Hz	60 Hz	60 Hz	16 FLT/ Alarm	5.3	0 Hz	60 Hz	4 kHz	Auto	Ramp	Not Sel	30 sec	30 sec
HK30WA353	HK30WA304	3.7 HP 230V	HD60FE656	230	11.2	60 Hz	1725	3.7	DI 2,3	40 Hz	60 Hz	60 Hz	16 FLT/ Alarm	12.9	0 Hz	60 Hz	4 kHz	Auto	Ramp	Not Sel	30 sec	30 sec
HK30WA357	HK30WA319	3.7 HP 460V	HD60FE656	460	5.6	60 Hz	1725	3.7	DI 2,3	40 Hz	60 Hz	60 Hz	16 FLT/ Alarm	6.4	0 Hz	60 Hz	4 kHz	Auto	Ramp	Not Sel	30 sec	30 sec
HK30WA361	HK30WA334	3.7 HP 575V	HD58FE577	575	4.2	60 Hz	175	3.7	DI 2,3	40 Hz	60 Hz	60 Hz	16 FLT/ Alarm	4.8	0 Hz	60 Hz	4 kHz	Auto	Ramp	Not Sel	30 sec	30 sec
HK30WA354	HK30WA305	5.0 HP 230V	HD60FK657	230	14.7	60 Hz	1760	5.0	DI 2,3	40 Hz	60 Hz	60 Hz	16 FLT/ Alarm	16.9	0 Hz	60 Hz	4 kHz	Auto	Ramp	Not Sel	30 sec	30 sec
HK30WA358	HK30WA320	5.0 HP 460V	HD60FK657	460	6.8	60 Hz	1760	5.0	DI 2,3	40 Hz	60 Hz	60 Hz	16 FLT/ Alarm	7.8	0 Hz	60 Hz	4 kHz	Auto	Ramp	Not Sel	30 sec	30 sec
HK30WA362	HK30WA335	5.0 HP 575V	HD60FL576	575	5.4	60 Hz	1745	5.0	DI 2,3	40 Hz	60 Hz	60 Hz	16 FLT/ Alarm	6.2	0 Hz	60 Hz	4 kHz	Auto	Ramp	Not Sel	30 sec	30 sec
HK30WA354	HK30WA305	7.5 HP 230V	HD62FK654	230	23.5	60 Hz	1760	7.5	DI 2,3	40 Hz	60 Hz	60 Hz	16 FLT/ Alarm	27.0	0 Hz	60 Hz	4 kHz	Auto	Ramp	Not Sel	30 sec	30 sec
HK30WA358	HK30WA320	7.5 HP 460V	HD62FK654	460	11.9	60 Hz	1760	7.5	DI 2,3	40 Hz	60 Hz	60 Hz	16 FLT/ Alarm	13.7	0 Hz	60 Hz	4 kHz	Auto	Ramp	Not Sel	30 sec	30 sec
HK30WA362	HK30WA335	7.5 HP 575V	HD62FL576	575	9.0	60 Hz	1750	7.5	DI 2,3	40 Hz	60 Hz	60 Hz	16 FLT/ Alarm	10.4	0 Hz	60 Hz	4 kHz	Auto	Ramp	Not Sel	30 sec	30 sec
HK30WA354	HK30WA305	5.0 HP 230V	HD60FL650	230	16.7	60 Hz	1740	5.0	DI 2,3	40 Hz	60 Hz	60 Hz	16 FLT/ Alarm	19.2	0 Hz	60 Hz	4 kHz	Auto	Ramp	Not Sel	30 sec	30 sec
HK30WA358	HK30WA320	5.0 HP 460V	HD60FL650	460	8.4	60 Hz	1740	5.0	DI 2,3	40 Hz	60 Hz	60 Hz	16 FLT/ Alarm	9.7	0 Hz	60 Hz	4 kHz	Auto	Ramp	Not Sel	30 sec	30 sec
HK30WA362	HK30WA335	5.0 HP 575V	HD60FL575	575	5.1	60 Hz	1725	5.0	DI 2,3	40 Hz	60 Hz	60 Hz	16 FLT/ Alarm	5.9	0 Hz	60 Hz	4 kHz	Auto	Ramp	Not Sel	30 sec	30 sec
HK30WA354	HK30WA305	5.3 HP 230V	HD60FK658	230	13.0	60 Hz	1740	5.3	DI 2,3	40 Hz	60 Hz	60 Hz	16 FLT/ Alarm	15.0	0 Hz	60 Hz	4 kHz	Auto	Ramp	Not Sel	30 sec	30 sec
HK30WA358	HK30WA320	5.3 HP 460V	HD60FK658	460	6.4	60 Hz	1740	5.3	DI 2,3	40 Hz	60 Hz	60 Hz	16 FLT/ Alarm	7.4	0 Hz	60 Hz	4 kHz	Auto	Ramp	Not Sel	30 sec	30 sec
HK30WA362	HK30WA335	5.3 HP 575V	HD60FE576	575	5.4	60 Hz	1725	5.3	DI 2,3	40 Hz	60 Hz	60 Hz	16 FLT/ Alarm	6.2	0 Hz	60 Hz	4 kHz	Auto	Ramp	Not Sel	30 sec	30 sec
HK30WA354	HK30WA305	7.5 HP 230V	HD62FL650	230	22.9	60 Hz	1745	7.5	DI 2,3	40 Hz	60 Hz	60 Hz	16 FLT/ Alarm	26.3	0 Hz	60 Hz	4 kHz	Auto	Ramp	Not Sel	30 sec	30 sec
HK30WA358	HK30WA320	7.5 HP 460V	HD62FL650	460	11.5	60 Hz	1745	7.5	DI 2,3	40 Hz	60 Hz	60 Hz	16 FLT/ Alarm	13.2	0 Hz	60 Hz	4 kHz	Auto	Ramp	Not Sel	30 sec	30 sec
HK30WA362	HK30WA335	7.5 HP 575V	HD62FL575	575	8.1	60 Hz	1745	7.5	DI 2,3	40 Hz	60 Hz	60 Hz	16 FLT/ Alarm	9.3	0 Hz	60 Hz	4 kHz	Auto	Ramp	Not Sel	30 sec	30 sec
HK30WA355	HK30WA306	10.0 HP 230V	HD64FK654	230	28.0	60 Hz	1755	10.0	DI 2,3	40 Hz	60 Hz	60 Hz	16 FLT/ Alarm	32.2	0 Hz	60 Hz	4 kHz	Auto	Ramp	Not Sel	30 sec	30 sec
HK30WA359	HK30WA321	10.0 HP 460V	HD64FK654	460	12.6	60 Hz	1755	10.0	DI 2,3	40 Hz	60 Hz	60 Hz	16 FLT/ Alarm	14.5	0 Hz	60 Hz	4 kHz	Auto	Ramp	Not Sel	30 sec	30 sec
HK30WA363	HK30WA336	10.0 HP 575V	HD64FL576	575	11.0	60 Hz	1755	10.0	DI 2,3	40 Hz	60 Hz	60 Hz	16 FLT/ Alarm	12.7	0 Hz	60 Hz	4 kHz	Auto	Ramp	Not Sel	30 sec	30 sec
HK30WA355	HK30WA306	10.0 HP 230V	HD64FL650	230	30.8	60 Hz	1745	10.0	DI 2,3	40 Hz	60 Hz	60 Hz	16 FLT/ Alarm	35.4	0 Hz	60 Hz	4 kHz	Auto	Ramp	Not Sel	30 sec	30 sec
HK30WA359	HK30WA321	10.0 HP 460V	HD64FL650	460	15.4	60 Hz	1745	10.0	DI 2,3	40 Hz	60 Hz	60 Hz	16 FLT/ Alarm	17.7	0 Hz	60 Hz	4 kHz	Auto	Ramp	Not Sel	30 sec	30 sec
HK30WA363	HK30WA336	10.0 HP 575V	HD64FL575	575	11.0	60 Hz	1740	10.0	DI 2,3	40 Hz	60 Hz	60 Hz	16 FLT/ Alarm	12.7	0 Hz	60 Hz	4 kHz	Auto	Ramp	Not Sel	30 sec	30 sec

**APPENDIX A — REMOTE VFD KEYPAD REFERENCE (CONT)**

**Table D — ACH550 VFD Parameters — 40RUA 07-30, 40RUS 08-30 and 40RUQ 07-25**

VFD PART NUMBER	DESC	MOTOR PART NUMBER	VOLT (9905)	NOM AMPS (9906)	MOTOR NOM FREQ (9907)	NOM RPM (9908)	NOM HP (9909)	CONST SPEED SEL (1201)	CONT SPEED 1 (1202)	CONST SPEED 2 (1203)	CONST SPEED 3 (1204)	RELAY OUT 3 (1403)	MAX AMPS (2003)	MIN FREQ (2007)	MAX FREQ (2008)	SWITCH FREQ (2606)	START FCN (2101)	STOP FCN (2102)	ACCEL/ DECEL (2201)	ACCEL (2202)	DECEL (2203)
HK30WA360	1.7 HP 575V	HD56FR579	575	2.8	60Hz	1725	1.7	DI 2,3	40Hz	60Hz	60Hz	16 FLT/Alarm	3.2	0Hz	60Hz	4kHz	Auto	Ramp	Not Sel	30s	30s
HK30WA360	2.4 HP 575V	HD56FE577	575	3.8	60Hz	1725	2.4	DI 2,3	40Hz	60Hz	60Hz	16 FLT/Alarm	4.4	0Hz	60Hz	4kHz	Auto	Ramp	Not Sel	30s	30s
HK30WA361	3.7 HP 575V	HD58FE577	575	4.9	60Hz	1725	3.7	DI 2,3	40Hz	60Hz	60Hz	16 FLT/Alarm	5.6	0Hz	60Hz	4kHz	Auto	Ramp	Not Sel	30s	30s
HK30WA361	3.7 HP 575V	HD58FE577	575	4.5	60Hz	1725	3.7	DI 2,3	40Hz	60Hz	60Hz	16 FLT/Alarm	5.2	0Hz	60Hz	4kHz	Auto	Ramp	Not Sel	30s	30s
HK30WA362	5.0 HP 575V	HD60FK577	575	8.0	60Hz	1725	5	DI 2,3	40Hz	60Hz	60Hz	16 FLT/Alarm	9.2	0Hz	60Hz	4kHz	Auto	Ramp	Not Sel	30s	30s
HK30WA362	7.5 HP 575V	HD62FL576	575	9.0	60Hz	1725	7.5	DI 2,3	40Hz	60Hz	60Hz	16 FLT/Alarm	10.4	0Hz	60Hz	4kHz	Auto	Ramp	Not Sel	30s	30s
HK30WA363	10 HP 575V	HD64FL576	575	11.0	60Hz	1725	10	DI 2,3	40Hz	60Hz	60Hz	16 FLT/Alarm	12.7	0Hz	60Hz	4kHz	Auto	Ramp	Not Sel	30s	30s
HK30WA360	1.7 HP 575V	HD56FR579	575	2.8	60Hz	1725	1.7	DI 3	40Hz	60Hz	60Hz	4 Fault	3.2	0Hz	60Hz	4kHz	Auto	Ramp	Not Sel	30s	30s
HK30WA360	2.4 HP 575V	HD56FE577	575	3.8	60Hz	1725	2.4	DI 3	40Hz	60Hz	60Hz	4 Fault	4.4	0Hz	60Hz	4kHz	Auto	Ramp	Not Sel	30s	30s
HK30WA361	3.7 HP 575V	HD58FE577	575	4.9	60Hz	1725	3.7	DI 3	40Hz	60Hz	60Hz	4 Fault	5.6	0Hz	60Hz	4kHz	Auto	Ramp	Not Sel	30s	30s
HK30WA361	3.7 HP 575V	HD58FE577	575	4.5	60Hz	1725	3.7	DI 3	40Hz	60Hz	60Hz	4 Fault	5.2	0Hz	60Hz	4kHz	Auto	Ramp	Not Sel	30s	30s

**APPENDIX A — REMOTE VFD KEYPAD REFERENCE (CONT)**

**Table E — ACS320 VFD Parameters — 48/50TC07-16 and 50TCQ07-14 (208/230V and 460V units only)**

VFD PART NUMBER	REPLACEMENT COMPONENT PART NUMBER	DESC	MOTOR PART NUMBER	VOLT (9905)	NOM AMPS (9906)	MOTOR NOM FREQ (9907)	NOM RPM (9908)	NOM HP (9909)	CONST SPEED SEL (1201)	CONT SPEED 1 (1202)	CONST SPEED 2 (1203)	CONST SPEED 3 (1204)	RELAY OUT 1 (1401)	MAX AMPS (2003)	MIN FREQ (2007)	MAX FREQ (2008)	SWITCH FREQ (2606)	START FCN (2101)	STOP FCN (2102)	ACCEL/ DECEL (2201)	ACCEL (2202)	DECEL (2203)
HK30WA523	HK30WA506	SRT 1.7 HP 230V	HD56FR233	230	5.8	60 Hz	1725	1.7	DI 2,3	40 Hz	60 Hz 60 Hz 60 Hz	60 Hz	16 FLT/ Alarm	6.7	0 Hz	60 Hz	4 kHz	Auto	Ramp	Not Sel	30 sec	30 sec
HK30WA530	HK30WA512	SRT 1.7 HP 460V	HD56FR463	460	2.9	60 Hz	1725	1.7	DI 2,3	40 Hz	60 Hz 60 Hz 60 Hz	60 Hz	16 FLT/ Alarm	3.3	0 Hz	60 Hz	4 kHz	Auto	Ramp	Not Sel	30 sec	30 sec
HK30WA523	HK30WA506	SRT 2.4 HP 230V	HD56FE653	230	7.9	60 Hz	1725	2.4	DI 2,3	40 Hz	60 Hz 60 Hz 60 Hz	60 Hz	16 FLT/ Alarm	9.1	0 Hz	60 Hz	4 kHz	Auto	Ramp	Not Sel	30 sec	30 sec
HK30WA530	HK30WA512	SRT 2.4 HP 460V	HD56FE653	460	3.6	60 Hz	1725	2.4	DI 2,3	40 Hz	60 Hz 60 Hz 60 Hz	60 Hz	16 FLT/ Alarm	4.1	0 Hz	60 Hz	4 kHz	Auto	Ramp	Not Sel	30 sec	30 sec
HK30WA523	HK30WA506	SRT 2.9 HP 230V	HD58FE654	230	9.2	60 Hz	1725	2.9	DI 2,3	40 Hz	60 Hz 60 Hz 60 Hz	60 Hz	16 FLT/ Alarm	10.6	0 Hz	60 Hz	4 kHz	Auto	Ramp	Not Sel	30 sec	30 sec
HK30WA530	HK30WA512	SRT 2.9 HP 460V	HD58FE654	460	4.2	60 Hz	1725	2.9	DI 2,3	40 Hz	60 Hz 60 Hz 60 Hz	60 Hz	16 FLT/ Alarm	4.8	0 Hz	60 Hz	4 kHz	Auto	Ramp	Not Sel	30 sec	30 sec
HK30WA523	HK30WA506	SRT 3.7 HP 230V	HD60FE656	230	11.7	60 Hz	1725	3.7	DI 2,3	40 Hz	60 Hz 60 Hz 60 Hz	60 Hz	16 FLT/ Alarm	13.5	0 Hz	60 Hz	4 kHz	Auto	Ramp	Not Sel	30 sec	30 sec
HK30WA534	HK30WA517	SRT 3.7 HP 460V	HD60FE656	460	5.4	60 Hz	1725	3.7	DI 2,3	40 Hz	60 Hz 60 Hz 60 Hz	60 Hz	16 FLT/ Alarm	6.2	0 Hz	60 Hz	4 kHz	Auto	Ramp	Not Sel	30 sec	30 sec
HK30WA524	HK30WA507	SRT 5.3 HP 230V	HD60FK658	230	13.6	60 Hz	1740	5.3	DI 2,3	40 Hz	60 Hz 60 Hz 60 Hz	60 Hz	16 FLT/ Alarm	15.6	0 Hz	60 Hz	4 kHz	Auto	Ramp	Not Sel	30 sec	30 sec
HK30WA532	HK30WA514	SRT 5.3 HP 460V	HD60FK658	460	6.4	60 Hz	1740	5.3	DI 2,3	40 Hz	60 Hz 60 Hz 60 Hz	60 Hz	16 FLT/ Alarm	7.4	0 Hz	60 Hz	4 kHz	Auto	Ramp	Not Sel	30 sec	30 sec
HK30WA523	HK30WA506	STR 2.9 HP 230V	HD58FE654	230	9.2	60 Hz	1725	2.9	DI 2,3	40 Hz	60 Hz 60 Hz 60 Hz	60 Hz	16 FLT/ Alarm	10.6	0 Hz	60 Hz	4 kHz	Auto	Ramp	Not Sel	30 sec	30 sec
47 HK30WA530	HK30WA512	STR 2.9 HP 460V	HD58FE654	460	4.2	60 Hz	1725	2.9	DI 2,3	40 Hz	60 Hz 60 Hz 60 Hz	60 Hz	16 FLT/ Alarm	4.8	0 Hz	60 Hz	4 kHz	Auto	Ramp	Not Sel	30 sec	30 sec
HK30WA523	HK30WA506	STR 3.7 HP 230V	HD60FE656	230	11.7	60 Hz	1725	3.7	DI 2,3	40 Hz	60 Hz 60 Hz 60 Hz	60 Hz	16 FLT/ Alarm	13.5	0 Hz	60 Hz	4 kHz	Auto	Ramp	Not Sel	30 sec	30 sec
HK30WA534	HK30WA517	STR 3.7 HP 460V	HD60FE656	460	5.4	60 Hz	1725	3.7	DI 2,3	40 Hz	60 Hz 60 Hz 60 Hz	60 Hz	16 FLT/ Alarm	6.2	0 Hz	60 Hz	4 kHz	Auto	Ramp	Not Sel	30 sec	30 sec
HK30WA524	HK30WA507	STR 5.0 HP 230V	HD60FK657	230	17.1	60 Hz	1760	5.0	DI 2,3	40 Hz	60 Hz 60 Hz 60 Hz	60 Hz	16 FLT/ Alarm	19.7	0 Hz	60 Hz	4 kHz	Auto	Ramp	Not Sel	30 sec	30 sec
HK30WA532	HK30WA514	STR 5.0 HP 460V	HD60FK657	460	8.6	60 Hz	1760	5.0	DI 2,3	40 Hz	60 Hz 60 Hz 60 Hz	60 Hz	16 FLT/ Alarm	9.9	0 Hz	60 Hz	4 kHz	Auto	Ramp	Not Sel	30 sec	30 sec

**APPENDIX A — REMOTE VFD KEYPAD REFERENCE (CONT)**

**Table F — ACS320 VFD Parameters — 48/50TC17-30 and 50TCQ17-24 (208/230V and 460V units only)**

VFD PART NUMBER	REPLACEMENT COMPONENT PART NUMBER	DESC	MOTOR PART NUMBER	VOLT (9905)	NOM AMPS (9906)	MOTOR NOM FREQ (9907)	NOM RPM (9908)	NOM HP (9909)	CONST SPEED SEL (1201)	CONT SPEED 1 (1202)	CONST SPEED 2 (1203)	CONST SPEED 3 (1204)	RELAY OUT 1 (1401)	MAX AMPS (2003)	MIN FREQ (2007)	MAX FREQ (2008)	SWITCH FREQ (2606)	START FCN (2101)	STOP FCN (2102)	ACCEL/ DECEL (2201)	ACCEL (2202)	DECEL (2203)
HK30WA523	HK30WA506	MRT 2.9 HP 230V	HD58FE654	230	9.2	60 Hz	1725	2.9	DI 2,3	40 Hz	60 Hz	60 Hz	16 FLT/ Alarm	10.6	0 Hz	60 Hz	4 kHz	Auto	Ramp	Not Sel	30 sec	30 sec
HK30WA530	HK30WA512	MRT 2.9 HP 460V	HD58FE654	460	4.2	60 Hz	1725	2.9	DI 2,3	40 Hz	60 Hz	60 Hz	16 FLT/ Alarm	4.8	0 Hz	60 Hz	4 kHz	Auto	Ramp	Not Sel	30 sec	30 sec
HK30WA523	HK30WA506	MRT 3.7 HP 230V	HD60FE656	230	11.7	60 Hz	1725	3.7	DI 2,3	40 Hz	60 Hz	60 Hz	16 FLT/ Alarm	13.5	0 Hz	60 Hz	4 kHz	Auto	Ramp	Not Sel	30 sec	30 sec
HK30WA534	HK30WA517	MRT 3.7 HP 460V	HD60FE656	460	5.4	60 Hz	1725	3.7	DI 2,3	40 Hz	60 Hz	60 Hz	16 FLT/ Alarm	6.2	0 Hz	60 Hz	4 kHz	Auto	Ramp	Not Sel	30 sec	30 sec
HK30WA524	HK30WA507	MRT 5.0 HP 230V	HD60FK657	230	17.1	60 Hz	1760	5.0	DI 2,3	40 Hz	60 Hz	60 Hz	16 FLT/ Alarm	19.7	0 Hz	60 Hz	4 kHz	Auto	Ramp	Not Sel	30 sec	30 sec
HK30WA532	HK30WA514	MRT 5.0 HP 460V	HD60FK657	460	8.6	60 Hz	1760	5.0	DI 2,3	40 Hz	60 Hz	60 Hz	16 FLT/ Alarm	9.9	0 Hz	60 Hz	4 kHz	Auto	Ramp	Not Sel	30 sec	30 sec
HK30WA524	HK30WA507	MRT 7.5 HP 230V	HD62FK654	230	23.5	60 Hz	1760	7.5	DI 2,3	40 Hz	60 Hz	60 Hz	16 FLT/ Alarm	27.0	0 Hz	60 Hz	4 kHz	Auto	Ramp	Not Sel	30 sec	30 sec
HK30WA532	HK30WA514	MRT 7.5 HP 460V	HD62FK654	460	11.9	60 Hz	1760	7.5	DI 2,3	40 Hz	60 Hz	60 Hz	16 FLT/ Alarm	13.7	0 Hz	60 Hz	4 kHz	Auto	Ramp	Not Sel	30 sec	30 sec
HK30WA524	HK30WA507	MRT 5.3 HP 230V	HD60FK658	230	13.6	60 Hz	1740	5.3	DI 2,3	40 Hz	60 Hz	60 Hz	16 FLT/ Alarm	15.6	0 Hz	60 Hz	4 kHz	Auto	Ramp	Not Sel	30 sec	30 sec
HK30WA532	HK30WA514	MRT 5.3 HP 460V	HD60FK658	460	6.4	60 Hz	1740	5.3	DI 2,3	40 Hz	60 Hz	60 Hz	16 FLT/ Alarm	7.4	0 Hz	60 Hz	4 kHz	Auto	Ramp	Not Sel	30 sec	30 sec
HK30WA525	HK30WA508	MRT 10.0 HP 230V	HD64FK654	230	30.4	60 Hz	1755	10.0	DI 2,3	40 Hz	60 Hz	60 Hz	16 FLT/ Alarm	35.0	0 Hz	60 Hz	4 kHz	Auto	Ramp	Not Sel	30 sec	30 sec
HK30WA533	HK30WA515	MRT 10.0 HP 460V	HD64FK654	460	15.2	60 Hz	1755	10.0	DI 2,3	40 Hz	60 Hz	60 Hz	16 FLT/ Alarm	17.1	0 Hz	60 Hz	4 kHz	Auto	Ramp	Not Sel	30 sec	30 sec



**APPENDIX A — REMOTE VFD KEYPAD REFERENCE (CONT)**

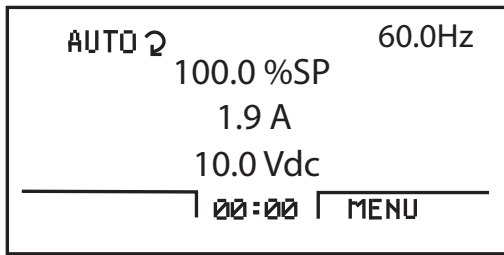
**Table G — ACS320 VFD Parameters — 40RU (208/230V and 460V units only)**

VFD PART NUMBER	REPLACEMENT COMPONENT PART NUMBER	DESC	MOTOR PART NUMBER	VOLT (9905)	NOM AMPS (9906)	MOTOR NOM FREQ (9907)	NOM RPM (9908)	NOM HP (9909)	CONST SPEED SEL (1201)	CONT SPEED 1 (1202)	CONST SPEED 2 (1203)	CONST SPEED 3 (1204)	RELAY OUT 1 (1403)	MAX AMPS (2003)	MIN FREQ (2007)	MAX FREQ (2008)	SWITCH FREQ (2606)	START FCN (2101)	STOP FCN (2102)	ACCEL/ DECEL (2201)	ACCEL (2202)	DECEL (2203)
HK30WA523	HK30WA506	1.7 HP 230V	HD56FR233	230	5.8	60Hz	1725	1.7	DI 2,3	40Hz	60Hz	60Hz	16 FLT/ Alarm	6.7	0Hz	60Hz	4kHz	Auto	(1) Coast	Not Sel	30 sec	30 sec
HK30WA530	HK30WA512	1.7 HP 460V	HD56FR463	460	2.9	60Hz	1725	1.7	DI 2,3	40Hz	60Hz	60Hz	16 FLT/ Alarm	3.3	0Hz	60Hz	4kHz	Auto	(1) Coast	Not Sel	30 sec	30 sec
HK30WA523	HK30WA506	2.4 HP 230V	HD56FE653	230	7.1	60Hz	1725	2.4	DI 2,3	40Hz	60Hz	60Hz	16 FLT/ Alarm	8.2	0Hz	60Hz	4kHz	Auto	(1) Coast	Not Sel	30 sec	30 sec
HK30WA530	HK30WA512	2.4 HP 460V	HD56FE653	460	3.4	60Hz	1725	2.4	DI 2,3	40Hz	60Hz	60Hz	16 FLT/ Alarm	3.9	0Hz	60Hz	4kHz	Auto	(1) Coast	Not Sel	30 sec	30 sec
HK30WA523	HK30WA506	2.9 HP 230V	HD58FE654	230	8.6	60Hz	1725	2.9	DI 2,3	40Hz	60Hz	60Hz	16 FLT/ Alarm	9.9	0Hz	60Hz	4kHz	Auto	(1) Coast	Not Sel	30 sec	30 sec
HK30WA530	HK30WA512	2.9 HP 460V	HD58FE654	460	3.8	60Hz	1725	2.9	DI 2,3	40Hz	60Hz	60Hz	16 FLT/ Alarm	4.4	0Hz	60Hz	4kHz	Auto	(1) Coast	Not Sel	30 sec	30 sec
HK30WA523	HK30WA506	3.7 HP 230V	HD60FE656	230	10.8	60Hz	1725	3.7	DI 2,3	40Hz	60Hz	60Hz	16 FLT/ Alarm	12.4	0Hz	60Hz	4kHz	Auto	(1) Coast	Not Sel	30 sec	30 sec
HK30WA534	HK30WA517	3.7 HP 460V	HD60FE656	460	4.9	60Hz	1725	3.7	DI 2,3	40Hz	60Hz	60Hz	16 FLT/ Alarm	5.6	0Hz	60Hz	4kHz	Auto	(1) Coast	Not Sel	30 sec	30 sec
HK30WA523	HK30WA506	3.7 HP 230V	HD58FR236	230	10.2	60Hz	1725	3.7	DI 2,3	40Hz	60Hz	60Hz	16 FLT/ Alarm	11.7	0Hz	60Hz	4kHz	Auto	(1) Coast	Not Sel	30 sec	30 sec
HK30WA534	HK30WA517	3.7 HP 460V	HD58FR236	460	4.8	60Hz	1725	3.7	DI 2,3	40Hz	60Hz	60Hz	16 FLT/ Alarm	5.5	0Hz	60Hz	4kHz	Auto	(1) Coast	Not Sel	30 sec	30 sec
HK30WA524	HK30WA507	5.0 HP 230V	HD60FK657	230	17.0	60Hz	1760	5	DI 2,3	40Hz	60Hz	60Hz	16 FLT/ Alarm	19.6	0Hz	60Hz	4kHz	Auto	(1) Coast	Not Sel	30 sec	30 sec
49 HK30WA532	HK30WA514	5.0 HP 460V	HD60FK657	460	7.6	60Hz	1760	5	DI 2,3	40Hz	60Hz	60Hz	16 FLT/ Alarm	8.7	0Hz	60Hz	4kHz	Auto	(1) Coast	Not Sel	30 sec	30 sec
HK30WA524	HK30WA507	7.5 HP 230V	HD62FK654	230	21.5	60Hz	1760	7.5	DI 2,3	40Hz	60Hz	60Hz	16 FLT/ Alarm	24.7	0Hz	60Hz	4kHz	Auto	(1) Coast	Not Sel	30 sec	30 sec
HK30WA532	HK30WA514	7.5 HP 460V	HD62FK654	460	14.3	60Hz	1760	7.5	DI 2,3	40Hz	60Hz	60Hz	16 FLT/ Alarm	16.4	0Hz	60Hz	4kHz	Auto	(1) Coast	Not Sel	30 sec	30 sec
HK30WA525	HK30WA508	10 HP 230V	HD64FK654	230	28	60Hz	1755	10	DI 2,3	40Hz	60Hz	60Hz	16 FLT/ Alarm	32.2	0Hz	60Hz	4kHz	Auto	(1) Coast	Not Sel	30 sec	30 sec
HK30WA533	HK30WA515	10 HP 460V	HD64FK654	460	15.2	60Hz	1755	10	DI 2,3	40Hz	60Hz	60Hz	16 FLT/ Alarm	17.5	0Hz	60Hz	4kHz	Auto	(1) Coast	Not Sel	30 sec	30 sec
HK30WA523	HK30WA506	1.7 HP 230V	HD56FR233	230	5.8	60Hz	1725	1.7	DI 2,3	40Hz	60Hz	60Hz	16 FLT/ Alarm	6.7	0Hz	60Hz	4kHz	(1) AUTO	(1) Coast	Not Sel	30 sec	10.0 sec
HK30WA530	HK30WA512	1.7 HP 460V	HD56FR463	460	2.9	60Hz	1725	1.7	DI 2,3	40Hz	60Hz	60Hz	16 FLT/ Alarm	3.3	0Hz	60Hz	4kHz	(1) AUTO	(1) Coast	Not Sel	30 sec	10.0 sec
HK30WA523	HK30WA506	2.4 HP 230V	HD56FE653	230	7.1	60Hz	1725	2.4	DI 2,3	40Hz	60Hz	60Hz	16 FLT/ Alarm	8.2	0Hz	60Hz	4kHz	(1) AUTO	(1) Coast	Not Sel	30 sec	10.0 sec
HK30WA530	HK30WA512	2.4 HP 460V	HD56FE653	460	3.4	60Hz	1725	2.4	DI 2,3	40Hz	60Hz	60Hz	16 FLT/ Alarm	3.9	0Hz	60Hz	4kHz	(1) AUTO	(1) Coast	Not Sel	30 sec	10.0 sec
HK30WA523	HK30WA506	3.7 HP 230V	HD60FE656	230	10.8	60Hz	1725	3.7	DI 2,3	40Hz	60Hz	60Hz	16 FLT/ Alarm	12.4	0Hz	60Hz	4kHz	(1) AUTO	(1) Coast	Not Sel	30 sec	10.0 sec
HK30WA534	HK30WA517	3.7 HP 460V	HD60FE656	460	4.9	60Hz	1725	3.7	DI 2,3	40Hz	60Hz	60Hz	16 FLT/ Alarm	5.6	0Hz	60Hz	4kHz	(1) AUTO	(1) Coast	Not Sel	30 sec	10.0 sec
HK30WA523	HK30WA506	3.7 HP 230V	HD58FR236	230	10.2	60Hz	1725	3.7	DI 2,3	40Hz	60Hz	60Hz	16 FLT/ Alarm	11.7	0Hz	60Hz	4kHz	(1) AUTO	(1) Coast	Not Sel	30 sec	10.0 sec
HK30WA534	HK30WA517	3.7 HP 460V	HD58FR236	460	4.8	60Hz	1725	3.7	DI 2,3	40Hz	60Hz	60Hz	16 FLT/ Alarm	5.5	0Hz	60Hz	4kHz	(1) AUTO	(1) Coast	Not Sel	30 sec	10.0 sec

## APPENDIX A — REMOTE VFD KEYPAD REFERENCE (CONT)

### Standard Display Mode

Use the standard display mode to read information on the drive status and operate the drive. To reach the standard display mode, press EXIT until the LCD display shows status information as described below. (See Fig. B.)



**Fig. B — Standard Display Example**

The top line of the LCD display shows the basic status information of the drive. The HAND icon indicates that the drive control is local from the control panel. The AUTO icon indicates that the drive is in remote control mode, such as the basic I/O or field bus.

The arrow icon indicates the drive and motor rotation status. A rotating arrow (clockwise or counterclockwise) indicates that the drive is running and at set point and the shaft direction is forward or reverse. A rotating blinking arrow indicates that the drive is running but not at set point. A stationary arrow indicates that the drive is stopped. For the units covered in this manual, the correct display rotation is clockwise.

The upper right corner shows the frequency set point that the drive will maintain.

Using parameter group 34, the middle of the LCD display can be configured to display 3 parameter values. The default display shows parameters 0103 (OUTPUT FREQ) in percent speed, 0104 (CURRENT) in amperes, and 0120 (A11) in voltage DC.

The bottom corners of the LCD display show the functions currently assigned to the two soft keys. The lower middle displays the current time (if configured to show the time).

The first time the drive is powered up, it is in the OFF mode. To switch to local hand-held control and control the drive using the control panel, press and hold the HAND button. Pressing the HAND button switches the drive to hand control while keeping the drive running. Press the AUTO button to switch to remote input control. To start the drive press the HAND or AUTO buttons, to stop the drive press the OFF button.

To adjust the speed in HAND mode, press the UP or DOWN buttons (the reference changes immediately). The reference can be modified in the local control (HAND) mode, and can be parameterized (using Group 11 reference select) to also allow modification in the remote control mode.

### Parameters Mode

The Parameters mode is used to change the parameters on the drive. To change parameters, perform the following procedure:

1. Select MENU (SOFT KEY 2). The Main menu will be displayed.
2. Use the UP or DOWN keys to highlight PARAMETERS on the display screen and press ENTER (SOFT KEY 2).
3. Use the UP or DOWN keys to highlight the desired parameter group and press SEL (SOFT KEY 2).
4. Use the UP or DOWN keys to highlight the desired parameter and press EDIT (SOFT KEY 2).
5. Use the UP or DOWN keys to change the value of the parameter.

6. Press SAVE (SOFT KEY 2) to store the modified value. Press CANCEL (SOFT KEY 1) to keep the previous value. Any modifications that are not saved will not be changed.
7. Choose another parameter or press EXIT (SOFT KEY 1) to return to the listing of parameter groups. Continue until all the parameters have been configured and then press EXIT (SOFT KEY 1) to return to the main menu.

NOTE: The current parameter value appears above the highlight parameter. To view the default parameter value, press the UP and DOWN keys simultaneously. To restore the default factory settings, select the Carrier application macro.

### Changed Parameters Mode

The Changed Parameters mode is used to view and edit recently changed parameters on the drive. To view the changed parameters, perform the following procedure:

1. Select MENU (SOFT KEY 2). The Main menu will be displayed.
2. Use the UP or DOWN keys to highlight CHANGED PAR on the display screen and press ENTER (SOFT KEY 2). A list of the recently changed parameters will be displayed.
3. Use the UP or DOWN keys to highlight the desired parameter group and press EDIT (SOFT KEY 2) to change the parameter if desired.
4. Press EXIT (SOFT KEY 1) to exit the Changed Parameters mode.

### Drive Parameter Backup Mode

The drive parameter back up mode is used to export the parameters from one drive to another. The parameters can be uploaded from a VFD to the removable control panel. The control panel can then be transferred to another drive and the parameters downloaded into memory.

Depending on the motor and application, there are two options available. The first option is to download all parameters. This copies both application and motor parameters to the drive from the control panel. This is recommended when using the same application for drives of the same size. This can also be used to create a backup of the parameters group for the drive.

The second option downloads only the application parameters to the drive. This is recommended when using the same application for drives of different sizes. Parameters 9905, 9906, 9907, 9908, 9909, 1605, 1607, 5201, and group 51 parameters and internal motor parameters are not copied.

### Upload All Parameters

To upload and store parameters in the control panel from the VFD, perform the following procedure:

1. Select MENU (SOFT KEY 2). The Main menu will be displayed.
2. Use the UP or DOWN keys to highlight PAR BACKUP on the display screen and press ENTER (SOFT KEY 2).
3. Use the UP or DOWN keys to highlight UPLOAD TO PANEL and press SEL (SOFT KEY 2).
4. The text “Copying Parameters” will be displayed with a progress indicator. To stop the process, select ABORT (SOFT KEY 1).
5. When the upload is complete, the text “Parameter upload successful” will be displayed.
6. The display will then return to the PAR BACKUP menu. Select EXIT (SOFT KEY 1) to return to the main menu.
7. The control panel can now be disconnected from the drive.

## APPENDIX A — REMOTE VFD KEYPAD REFERENCE (CONT)

### DOWNLOAD ALL PARAMETERS

To download all parameters from the control panel to the VFD, perform the following procedure:

1. Install the control panel with the correct parameters onto the VFD.
2. Select MENU (SOFT KEY 2). The Main menu will be displayed.
3. Use the UP or DOWN keys to highlight PAR BACKUP on the display screen and press ENTER (SOFT KEY 2).
4. Use the UP or DOWN keys to highlight DOWNLOAD TO DRIVE ALL and press SEL (SOFT KEY 2).
5. The text “Restoring Parameters” will be displayed with a progress indicator. To stop the process, select ABORT (SOFT KEY 1).
6. When the download is complete, the text “Parameter download successful” will be displayed.
7. The display will then return to the PAR BACKUP menu. Select EXIT (SOFT KEY 1) to return to the main menu.
8. The control panel can now be disconnected from the drive.

### DOWNLOAD APPLICATION PARAMETERS

To download application parameters only to the control panel from the VFD, perform the following procedure:

1. Install the control panel with the correct parameters onto the VFD.
2. Select MENU (SOFT KEY 2). The Main menu will be displayed.
3. Use the UP or DOWN keys to highlight PAR BACKUP on the display screen and press ENTER (SOFT KEY 2).
4. Use the UP or DOWN keys to highlight DOWNLOAD APPLICATION and press SEL (SOFT KEY 2).
5. The text “Downloading Parameters (partial)” will be displayed with a progress indicator. To stop the process, select ABORT (SOFT KEY 1).
6. When the download is complete, the text “Parameter download successful” will be displayed.
7. The display will then return to the PAR BACKUP menu. Select EXIT (SOFT KEY 1) to return to the main menu.
8. The control panel can now be disconnected from the drive.

### Clock Set Mode

Use the clock set mode to set the date and time for the internal clock of the VFD. In order to use the timer functions of the VFD control, the internal clock must be set. The date is used to determine weekdays and is visible in the fault logs.

To set the clock, perform the following procedure:

1. Select MENU (SOFT KEY 2). The Main menu will be displayed.
2. Use the UP or DOWN keys to highlight CLOCK SET on the display screen and press ENTER (SOFT KEY 2). The clock set parameter list will be displayed.
3. Use the UP or DOWN keys to highlight CLOCK VISIBILITY and press SEL (SOFT KEY 2). This parameter is used to display or hide the clock on the screen. Use the UP or DOWN keys to change the parameter setting. Press OK (SOFT KEY 2) to save the configuration and return to the Clock Set menu.
4. Use the UP or DOWN keys to highlight SET TIME and press SEL (SOFT KEY 2). Use the UP or DOWN keys to change the hours and minutes. Press OK (SOFT KEY 2) to save the configuration and return to the Clock Set menu.
5. Use the UP or DOWN keys to highlight TIME FORMAT and press SEL (SOFT KEY 2). Use the UP or DOWN

keys to change the parameter setting. Press OK (SOFT KEY 2) to save the configuration and return to the Clock Set menu.

6. Use the UP or DOWN keys to highlight SET DATE and press SEL (SOFT KEY 2). Use the UP or DOWN keys to change the day, month, and year. Press OK (SOFT KEY 2) to save the configuration and return to the Clock Set menu.
7. Use the UP or DOWN keys to highlight DATE FORMAT and press SEL (SOFT KEY 2). Use the UP or DOWN keys to change the parameter setting. Press OK (SOFT KEY 2) to save the configuration and return to the Clock Set menu.
8. Press EXIT (SOFT KEY 1) twice to return to the main menu.

### I/O Settings Mode

Use the I/O Settings mode to view and edit the I/O settings.

To configure the I/O settings, perform the following procedure:

1. Select MENU (SOFT KEY 2). The Main menu will be displayed.
2. Use the UP or DOWN keys to highlight I/O SETTINGS on the display screen and press ENTER (SOFT KEY 2). The I/O Settings parameter list will be displayed.
3. Use the UP or DOWN keys to highlight the desired I/O setting and press SEL (SOFT KEY 2).
4. Use the UP or DOWN keys to select the parameter to view. Press OK (SOFT KEY 2).
5. Use the UP or DOWN keys to change the parameter setting. Press SAVE (SOFT KEY 2) to save the configuration. Press CANCEL (SOFT KEY 1) to keep the previous value. Any modifications that are not saved will not be changed.
6. Press EXIT (SOFT KEY 1) twice to return to the main menu.

### VFD DIAGNOSTICS

The drive detects error situations and reports them using:

1. Green and red LEDs on the body of the drive (located under the keypad)
2. Status LED on the control panel
3. Control panel display
4. The Fault Word and Alarm Word parameter bits (parameters 0305 to 0309)

The form of the display depends on the severity of the error. The user can specify the severity for many errors by directing the drive to ignore the error situation, report the situation as an alarm, or report the situation as a fault.

### Faults (Red LED Lit)

The VFD signals that it has detected a severe error, or fault, by:

1. Enabling the red LED on the drive (LED is either steady or flashing)
2. Setting an appropriate bit in a Fault Word parameter (0305 to 0307)
3. Overriding the control panel display with the display of a fault code
4. Stopping the motor (if it was on)

## APPENDIX A — REMOTE VFD KEYPAD REFERENCE (CONT)

The fault code on the control panel display is temporary. Pressing the MENU, ENTER, UP button or DOWN buttons removes the fault message. The message reappears after a few seconds if the control panel is not touched and the fault is still active. See Table H for a list of fault codes.

### Alarms (Green LED Flashing)

For less severe errors, called alarms, the diagnostic display is advisory. For these situations, the drive is simply reporting that it had detected something unusual. In these situations, the drive:

1. Flashes the green LED on the drive (does not apply to alarms that arise from control panel operation errors)
2. Sets an appropriate bit in an Alarm Word parameter (0308 or 0309)
3. Overrides the control panel display with the display of an alarm code and/or name

Alarm messages disappear from the control panel display after a few seconds. The message returns periodically as long as the alarm condition exists. See Table I for a list of alarm codes.

### Correcting Faults

The recommended corrective action for faults is shown in the Fault Listing Table H. The VFD can also be reset to remove the fault. If an external source for a start command is selected and is active, the VFD may start immediately after fault reset.

To reset a fault indicated by a flashing red LED, turn off the power for 5 minutes. To reset a fault indicated by a red LED (not flashing), press RESET from the control panel or turn off the power for 5 minutes. Depending on the value of parameter 1604 (FAULT RESET SELECT), digital input or serial communication could also be used to reset the drive. When the fault has been corrected, the motor can be started.

### History

For reference, the last three fault codes are stored into parameters 0401, 0412, 0413. For the most recent fault (identified by parameter 0401), the drive stores additional data (in parameters 0402 - 0411) to aid in troubleshooting a problem. For example, a parameter 0404 stores the motor speed at the time of the fault. To clear the fault history (all of Group 04, Fault History parameters), follow these steps:

1. In the control panel, Parameters mode, select parameter 0401.
2. Press EDIT.
3. Press the UP and DOWN buttons simultaneously.
4. Press SAVE.

### Correcting Alarms

To correct alarms, first determine if the alarm requires any corrective action (action is not always required). Use Table I to find and address the root cause of the problem.

If diagnostics troubleshooting has determined that the drive is defective during the warranty period, contact Carrier.

### Control Panel Cleaning

Use a soft damp cloth to clean the control panel. Avoid harsh cleaners which could scratch the display window.

### Battery Replacement

A battery is only used in assistant control panels that have the clock function available and enabled. The battery keeps the clock operating in memory during power interruptions. The expected life for the battery is greater than ten years. To remove the battery, use a coin to rotate the battery holder on the back of the control panel. Replace the battery with type CR2032.

Table H — Fault Codes

FAULT CODE	FAULT NAME IN PANEL	DESCRIPTION AND RECOMMENDED CORRECTIVE ACTION
1	OVERCURRENT	Output current is excessive. Check for excessive motor load, insufficient acceleration time (parameters 2202 ACCELER TIME 1, default 30 seconds), or faulty motor, motor cables or connections.
2	DC OVERVOLT	Intermediate circuit DC voltage is excessive. Check for static or transient over voltages in the input power supply, insufficient deceleration time (parameters 2203 DECELER TIME 1, default 30 seconds), or undersized brake chopper (if present).
3	DEV OVERTEMP	Drive heat sink is overheated. Temperature is at or above 115°C (239°F). Check for fan failure, obstructions in the air flow, dirt or dust coating on the heat sink, excessive ambient temperature, or excessive motor load.
4	SHORT CIRC	Fault current. Check for short-circuit in the motor cable(s) or motor or supply disturbances.
5	OVERLOAD	Inverter overload condition. The drive output current exceeds the ratings.
6	DC OVERVOLT	Intermediate circuit DC voltage is not sufficient. Check for missing phase in the input power supply, blown fuse, or under voltage on main circuit.
7	AI1 LOSS	Analog input 1 loss. Analog input value is less than AI1 FLT LIMIT (3021). Check source and connection for analog input and parameter settings for AI1 FLT LIMIT (3021) and 3001 AI-MIN FUNCTION.
8	AI2 LOSS	Analog input 2 loss. Analog input value is less than AI2 FLT LIMIT (3022). Check source and connection for analog input and parameter settings for AI2 FLT LIMIT (3022) and 3001 AI-MIN FUNCTION.
9	MOT OVERTEMP	Motor is too hot, as estimated by the drive. Check for overloaded motor. Adjust the parameters used for the estimate (3005 - 3009). Check the temperature sensors and Group 35 parameters.
10	PANEL LOSS	Panel communication is lost and either drive is in local control mode (the control panel displays LOC), or drive is in remote control mode (REM) and is parameterized to accept start/stop, direction or reference from the control panel. To correct check the communication lines and connections. Check parameter 3002 PANEL COMM ERROR, parameters in Group 10: Command Inputs and Group 11:Reference Select (if drive operation is REM).
11	ID RUN FAIL	The motor ID run was not completed successfully. Check motor connections.
12	MOTOR STALL	Motor or process stall. Motor is operating in the stall region. Check for excessive load or insufficient motor power. Check parameters 3010 - 3012.
13	RESERVED	Not used.
14	EXT FAULT 1	Digital input defined to report first external fault is active. See parameter 3003 EXTERNAL FAULT 1.
15	EXT FAULT 2	Digital input defined to report second external fault is active. See parameter 3004 EXTERNAL FAULT 2.
16	EARTH FAULT	The load on the input power system is out of balance. Check for faults in the motor or motor cable. Verify that motor cable does not exceed maximum specified length.
17	UNDERLOAD	Motor load is lower than expected. Check for disconnected load. Check parameters 3013 UNDERLOAD FUNCTION through 3015 UNDERLOAD CURVE.
18	THERM FAIL	Internal fault. The thermistor measuring the internal temperature of the drive is open or shorted. Contact Carrier.

## APPENDIX A — REMOTE VFD KEYPAD REFERENCE (CONT)

### Table H — Fault Codes (cont)

FAULT CODE	FAULT NAME IN PANEL	DESCRIPTION AND RECOMMENDED CORRECTIVE ACTION
19	OPEX LINK	Internal fault. A communication-related problem has been detected between the OMIO and OINT boards. Contact Carrier.
20	OPEX PWR	Internal fault. Low voltage condition detected on the OINT board. Contact Carrier.
21	CURR MEAS	Internal fault. Current measurement is out of range. Contact Carrier.
22	SUPPLY PHASE	Ripple voltage in the DC link is too high. Check for missing main phase or blown fuse.
23	RESERVED	Not used.
24	OVERSPEED	Motor speed is greater than 120% of the larger (in magnitude) of 2001 MINIMUM SPEED or 2002 MAXIMUM SPEED parameters. Check parameter settings for 2001 and 2002. Check adequacy of motor braking torque. Check applicability of torque control. Check brake chopper and resistor.
25	RESERVED	Not used.
26	DRIVE ID	Internal fault. Configuration block drive ID is not valid.
27	CONFIG FILE	Internal configuration file has an error. Contact Carrier.
28	SERIAL 1 ERR	Field bus communication has timed out. Check fault setup (3018 COMM FAULT FUNC and 3019 COMM FAULT TIME). Check communication settings (Group 51 or 53 as appropriate). Check for poor connections and/or noise on line.
29	EFB CON FILE	Error in reading the configuration file for the field bus adapter.
30	FORCE TRIP	Fault trip forced by the field bus. See the field bus reference literature.
31	EFB 1	Fault code reserved for the EFB protocol application. The meaning is protocol dependent.
32	EFB 2	Fault code reserved for the EFB protocol application. The meaning is protocol dependent.
33	EFB 3	Fault code reserved for the EFB protocol application. The meaning is protocol dependent.
34	MOTOR PHASE	Fault in the motor circuit. One of the motor phases is lost. Check for motor fault, motor cable fault, thermal relay fault, or internal fault.
35	OUTP WIRING	Error in power wiring suspected. Check that input power wired to drive output. Check for ground faults.
<b>101 - 105</b>	<b>SYSTEM ERROR</b>	Error internal to the drive. Contact Carrier and report the error number.
<b>1000</b>	<b>PAR HZRPM</b>	Parameter values are inconsistent. Check for any of the following: 2001 MINIMUM SPEED > 2002 MAXIMUM SPEED 2007 MINIMUM FREQ > 2008 MAXIMUM FREQ 2001 MINIMUM SPEED / 9908 MOTOR NOM SPEED is outside of the range: -128/+128 2002 MAXIMUM SPEED / 9908 MOTOR NOM SPEED is outside of the range: -128/+128 2007 MINIMUM FREQ / 9907 MOTOR NOM FREQ is outside of the range: -128/+128 2008 MAXIMUM FREQ / 9907 MOTOR NOM FREQ is outside of the range: -128/+128
<b>1001</b>	<b>PAR PFA REFNG</b>	Parameter values are inconsistent. Check that 2007 MINIMUM FREQ is negative, when 8123 PFA ENABLE is active.
<b>1002</b>	<b>PAR PFA IOCNF</b>	Parameter values are inconsistent. The number of programmed PFA relays does not match with Interlock configuration, when 8123 PFA ENABLE is active. Check consistency of RELAY OUTPUT parameters 1401 - 1403, and 1410 - 1412. Check 8117 NR OF AUX MOTORS, 8118 AUTOCHANGE INTERV, and 8120 INTERLOCKS.
<b>1003</b>	<b>PAR AI SCALE</b>	Parameter values are inconsistent. Check that parameter 1301 AI 1 MIN > 1302 AI 1 MAX and that parameter 1304 AI 2 MIN > 1305 AI 2 MAX.
<b>1004</b>	<b>PAR AO SCALE</b>	Parameter values are inconsistent. Check that parameter 1504 AO 1 MIN > 1505 AO 1 MAX and that parameter 1510 AO 2 MIN > 1511 AO 2 MAX.
<b>1005</b>	<b>PAR PCU 2</b>	Parameter values for power control are inconsistent: Improper motor nominal kVA or motor nominal power. Check the following parameters: $1.1 < (9906 \text{ MOTOR NOM CURR} * 9905 \text{ MOTOR NOM VOLT} * 1.73 / \text{PN}) < 2.6$ Where: PN = 1000 * 9909 MOTOR NOM POWER (if units are kW) or PN = 746 * 9909 MOTOR NOM POWER (if units are HP, e.g., in US)
<b>1006</b>	<b>PAR EXT RO</b>	Parameter values are inconsistent. Check the extension relay module for connection and 1410 - 1412 RELAY OUTPUTS 4 - 6 have non-zero values.
<b>1007</b>	<b>PAR FBUS</b>	Parameter values are inconsistent. Check that a parameter is set for field bus control (e.g., 1001 EXT1 COMMANDS = 10 (COMM)), but 9802 COMM PROT SEL = 0.
<b>1008</b>	<b>PAR PFA MODE</b>	Parameter values are inconsistent. The 9904 MOTOR CTRL MODE must = 3 (SCALAR SPEED) when 8123 PFA ENABLE activated.
<b>1009</b>	<b>PAR PCU 1</b>	Parameter values for power control are inconsistent or improper motor nominal frequency or speed. Check for both of the following: $1 < (60 * 9907 \text{ MOTOR NOM FREQ} / 9908 \text{ MOTOR NOM SPEED}) < 16$ $0.8 < 9908 \text{ MOTOR NOM SPEED} / (120 * 9907 \text{ MOTOR NOM FREQ} / \text{Motor poles}) < 0.992$
<b>1010</b>	<b>OVERRIDE/PFA CONFLICT</b>	Override mode is enabled and PFA is activated at the same time. This cannot be done because PFA interlocks cannot be observed in the override mode.

## APPENDIX A — REMOTE VFD KEYPAD REFERENCE (CONT)

### Table I — ALARM CODES

ALARM CODE	ALARM NAME IN PANEL	DESCRIPTION AND RECOMMENDED CORRECTIVE ACTION
2001	—	Reserved
2002	—	Reserved
2003	—	Reserved
2004	DIR LOCK	The change in direction being attempted is not allowed. Do not attempt to change the direction of motor rotation, or Change parameter 1003 DIRECTION to allow direction change (if reverse operation is safe).
2005	I/O COMM	Field bus communication has timed out. Check fault setup (3018 COMM FAULT FUNC and 3019 COMM FAULT TIME). Check communication settings (Group 51 or 53 as appropriate). Check for poor connections and/or noise on line.
2006	AL1 LOSS	Analog input 1 is lost, or value is less than the minimum setting. Check input source and connections. Check the parameter that sets the minimum (3021) and the parameter that sets the Alarm/Fault operation (3001).
2007	AL2 LOSS	Analog input 2 is lost, or value is less than the minimum setting. Check input source and connections. Check parameter that sets the minimum (3022) and the parameter that sets the Alarm/Fault operation (3001).
2008	PANEL LOSS	Panel communication is lost and either the VFD is in local control mode (the control panel displays HAND), or the VFD is in remote control mode (AUTO) and is parameterized to accept start/stop, direction or reference from the control panel. To correct, check the communication lines and connections, Parameter 3002 PANEL LOSS, and parameters in groups 10 COMMAND INPUTS and 11 REFERENCE SELECT (if drive operation is REM).
2009	—	Reserved
2010	MOT OVERTEMP	Motor is hot, based on either the VFD estimate or on temperature feedback. This alarm warns that a Motor Overload fault trip may be near. Check for overloaded motor. Adjust the parameters used for the estimate (3005 - 3009). Check the temperature sensors and Group 35 parameters.
2011	UNDERLOAD	Motor load is lower than expected. This alarm warns that a Motor Underload fault trip may be near. Check that the motor and drive ratings match (motor is NOT undersized for the drive). Check the settings on parameters 3013 to 3015.
2012	MOTOR STALL	Motor is operating in the stall region. This alarm warns that a Motor Stall fault trip may be near.
2013*	AUTORESET	This alarm warns that the drive is about to perform an automatic fault reset, which may start the motor. To control automatic reset, use parameter group 31 (AUTOMATIC RESET).
2014	AUTOCHANGE	This alarm warns that the PFA autochange function is active. To control PFA, use parameter group 81 (PFA) and the Pump Alternation macro.
2015	PFA INTERLOCK	This alarm warns that the PFA interlocks are active, which means that the drive cannot start any motor (when Autochange is used), or a speed regulated motor (when Autochange is not used).
2016	—	Reserved
2017*	OFF BUTTON	This alarm indicates that the OFF button has been pressed.
2018	PID SLEEP	This alarm warns that the PID sleep function is active, which means that the motor could accelerate when the PID sleep function ends. To control PID sleep, use parameters 4022 - 4026 or 4122 - 4126.
2019	ID RUN	The VFD is performing an ID run.
2020	OVERRIDE	Override mode is activated.
2021	START ENABLE 1 MISSING	This alarm warns that the Start Enable 1 signal is missing. To control Start Enable 1 function, use parameter 1608. To correct, check the digital input configuration and the communication settings.
2022	START ENABLE 2 MISSING	This alarm warns that the Start Enable 2 signal is missing. To control Start Enable 2 function, use parameter 1609. To correct, check the digital input configuration and the communication settings.
2023	EMERGENCY STOP	Emergency stop is activated.

\* This alarm is not indicated by a relay output, even when the relay output is configured to indicate alarm conditions, parameter 1401 RELAY OUTPUT = 5 (ALARM) or 16 (FLT/ALARM).

## APPENDIX A — REMOTE VFD KEYPAD REFERENCE (CONT)

### Reset After Using Start-Up Assistant

#### ⚠ CAUTION

##### CONFIGURATION OVERRIDE HAZARD

DO NOT USE ABB OR CARRIER START-UP ASSISTANT ON THIS VFD APPLICATION! Use of start-up assistant will override the factory VFD configurations!

The following section details how to reset the VFD after accidentally using Start-Up Assistant.

When the VFD has been incorrectly programmed by using Start-Up Assistant, the drive may be locked in an override loop because of motor ID Run Fail (error code 11) and First Start (error code 2025).

Use the following procedure to reset the factory configurations for ACS320 VFDs:

1. Disconnect unit power. Lock-out/tag out.
2. Remove the VFD's terminal cover.
3. Disconnect the DI1 input at terminal 12. The terminals are numbered on the bottom of the block (see Fig. C for the location of terminal block that contains terminal 12).

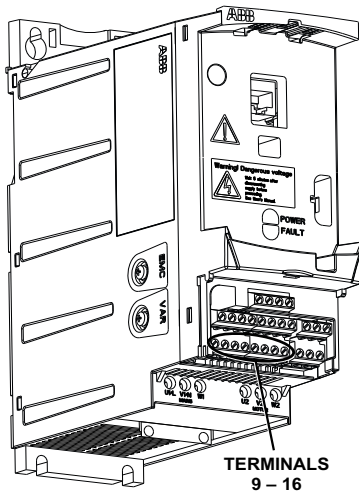


Fig. C — ACS320 Terminal Blocks

4. Connect the VFD Keypad accessory to the VFD (if not already connected).

NOTE: The VFD Keypad is a field-installed accessory; it is not included with the factory-installed VFD option.

5. With the wire disconnected, use the keypad to stop the loop and enter “358” in parameter 1704 OVERRIDE PASS CODE.
6. Go immediately to parameter 1705 OVERRIDE ENABLE and select “Off”.
7. At this point, providing you have a clean backup of the drive, you can select “DOWNLOAD FULL SET” from ‘PAR BACKUP’ from the Main Menu.  
If you do not have a clean backup the drive will have to be manually programmed following the instructions in this document.

8. When the correct parameters have been uploaded, disconnect power to the unit, reconnect DI1 to Terminal 12, and replace the terminal cover.
9. Reconnect power to the unit. The VFD is now commissioned from the backup file.

Use the following procedure to reset the factory configurations for ACH550 VFDs:

1. Disconnect unit power. Lock-out/tag-out.
2. Remove the VFD's front cover (see Fig. 38 on page 31).
3. Disconnect the DI1 input at Terminal 13 (see Fig. D for location of DI1).
4. Connect the VFD Keypad accessory to the VFD (if not already connected).

NOTE: The VFD Keypad is a field-installed accessory; it is not included with the factory-installed VFD option.

5. With the wire disconnected, use the keypad to stop the loop and enter “358” in parameter 1704 OVERRIDE PASS CODE.
6. Go immediately to parameter 1705 OVERRIDE ENABLE and select “Off”.
7. At this point, providing you have a clean backup of the drive, you can select “DOWNLOAD FULL SET” from “PAR BACKUP” from the Main Menu.
8. If you do not have a clean backup the drive will have to be manually programmed following the instructions in this document.
9. When the correct parameters have been uploaded, disconnect power to the unit, reconnect DI1 to Terminal 13, and replace the VFD cover.
10. Reconnect power to the unit. The VFD is now commissioned from the backup file.

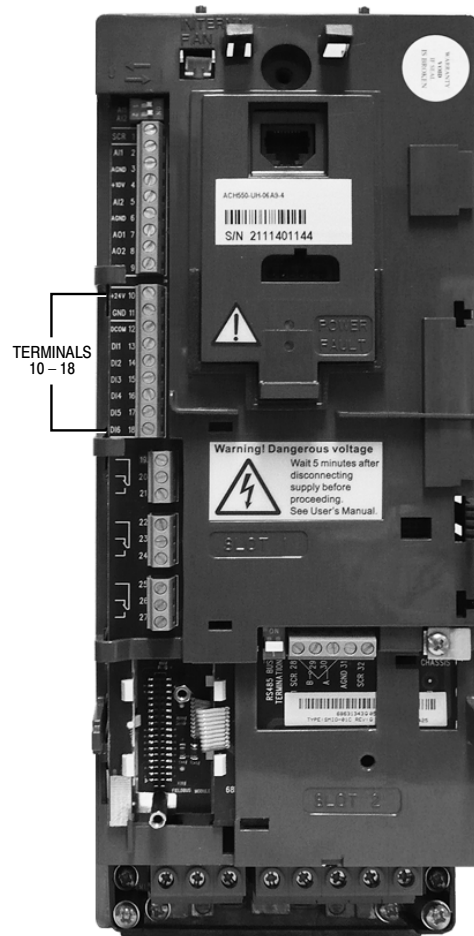


Fig. D — Terminal Block Location on ACH550 VFD

